

**This electronic collection of documents is provided
for the convenience of the user
and is Not a Certified Document-**

**The documents contained herein were originally issued
and sealed by the individuals whose names and license
numbers appear on each page, on the dates appearing
with their signature on that page.**

**This file or an individual page
shall not be considered a certified document.**

09/08/19

PROJECT WBS: 17BP.9.R.82

See Sheet 1A For Index of Sheets
See Sheet 1B For Standard Symbology Sheet

STATE OF NORTH CAROLINA
DIVISION OF HIGHWAYS

ROWAN COUNTY

**LOCATION: BRIDGE #248 OVER GRANTS CREEK
ON SR 1211 (KIMBALL RD)**
TYPE OF WORK: GRADING, PAVING, DRAINAGE, & STRUCTURE

STATE	STATE PROJECT REFERENCE NO.	SHEET NO.	TOTAL SHEETS
N.C.	17BP.9.R.82	1	
STATE PROJ. NO.	F.A. PROJ. NO.	DESCRIPTION	
17BP.9.R.82		P.E.	
17BP.9.R.82		ROW	
17BP.9.R.82		CONSTRUCTION	

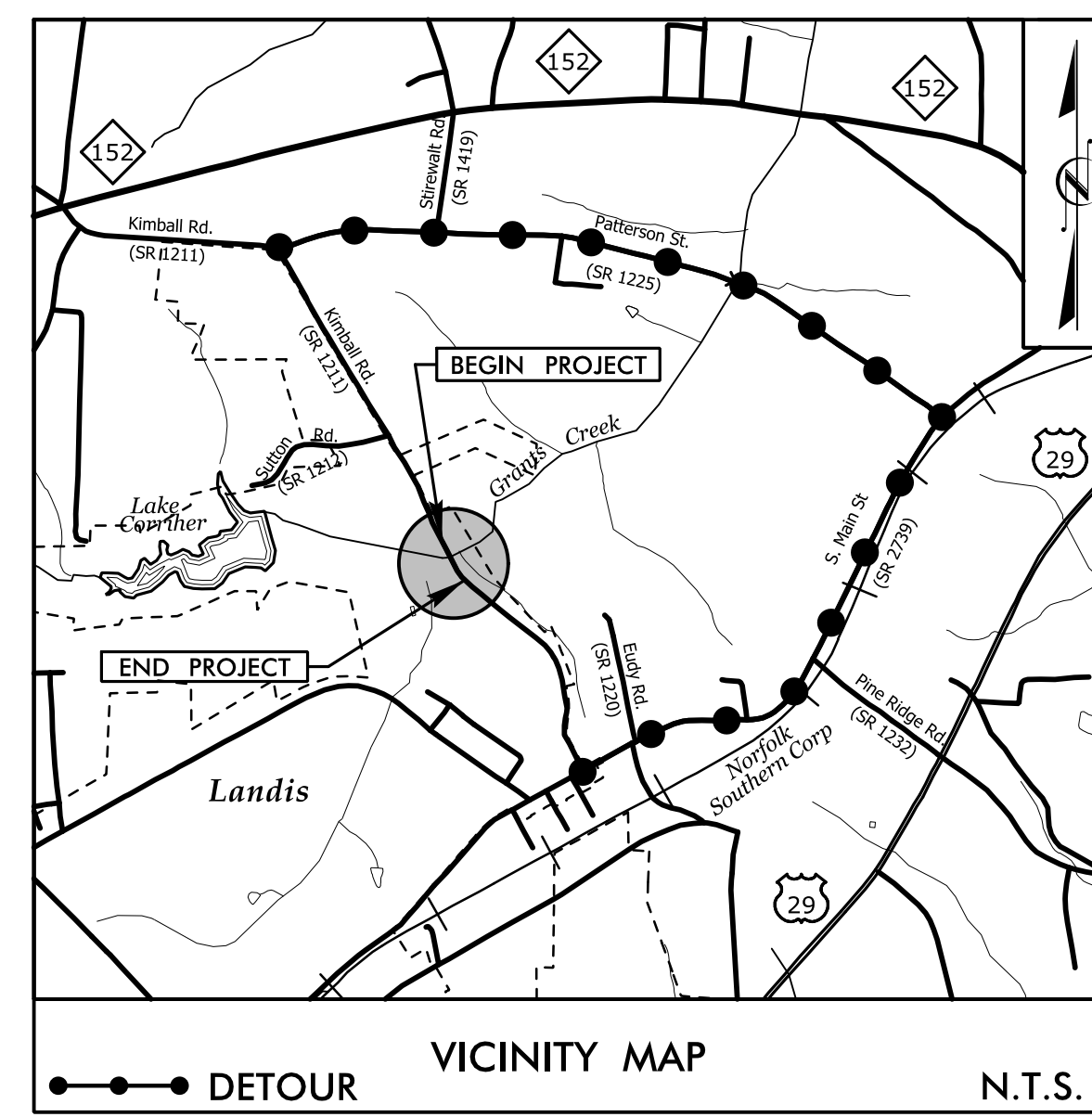
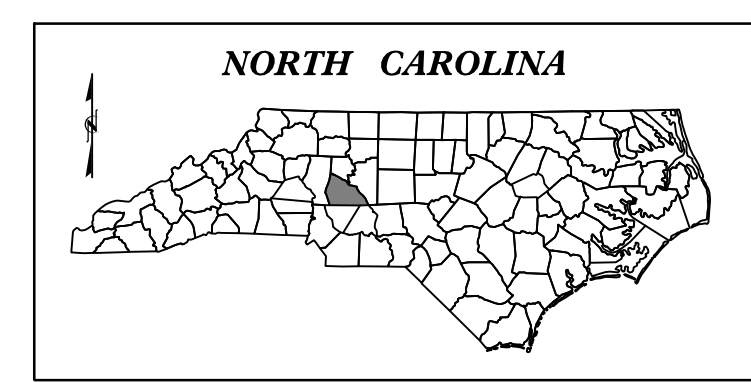

FINAL PLANS

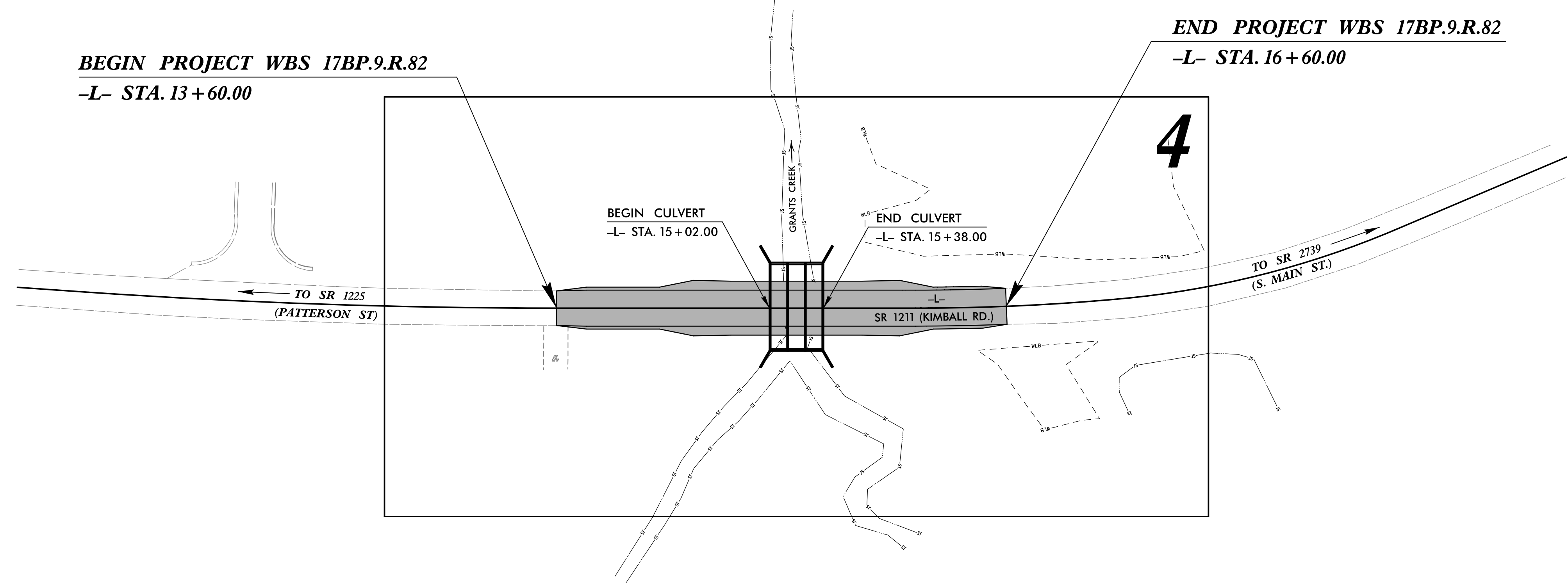
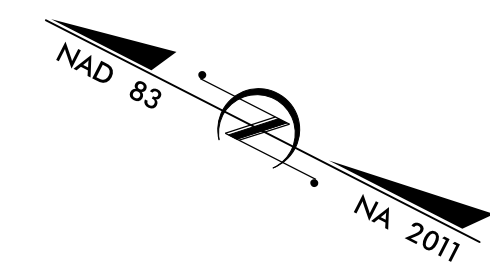

**DOCUMENT NOT CONSIDERED FINAL
UNLESS ALL SIGNATURES COMPLETED**

CONTRACT:

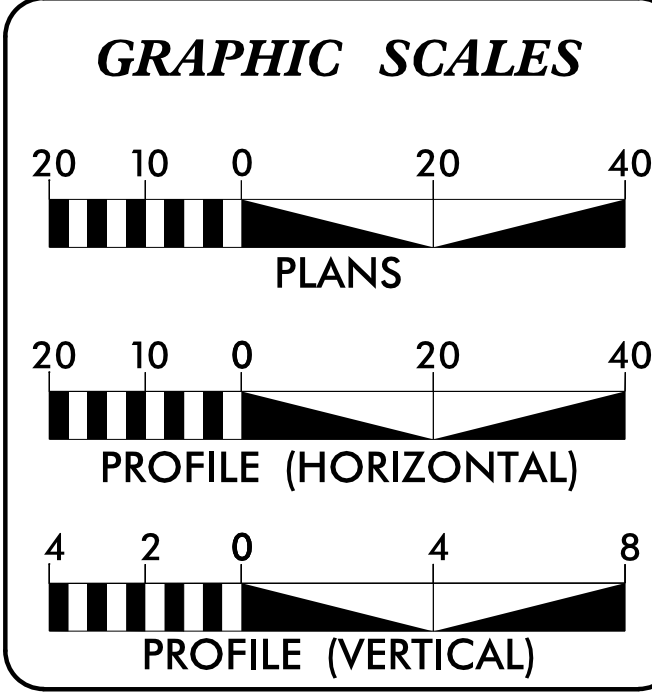

DESIGN DATA

ADT 2012 =	2800
ADT 2025 =	5600
DHV =	N/A
D =	N/A
T =	7 %
V =	35 MPH

FUNC. CLASSIFICATION:
COLLECTOR

PROJECT LENGTH

LENGTH OF ROADWAY PROJECT WBS 17BP.9.R.82 =	0.050 MILES
LENGTH OF STRUCTURE PROJECT WBS 17BP.9.R.82 =	0.007 MILES
TOTAL LENGTH OF PROJECT WBS 17BP.9.R.82 =	0.057 MILES

NCDOT CONTACT: DANIEL DAGENHART
Division Bridge Manager

PLANS PREPARED FOR THE NCDOT BY:

STV 100 Years
STV Engineers, Inc.
900 West Trade St., Suite 715
Charlotte, NC 28202
NC License Number F-0991

RIGHT OF WAY DATE: AUGUST 31, 2021	NIKKI T. HONEYCUTT, PE PROJECT ENGINEER
LETTING DATE: JUNE 15, 2022	MAAMOON K. ABDELAZIZ PROJECT DESIGNER

HYDRAULICS ENGINEER
4/25/2022

ROADWAY DESIGN ENGINEER
4/26/2022

SIGNATURE:

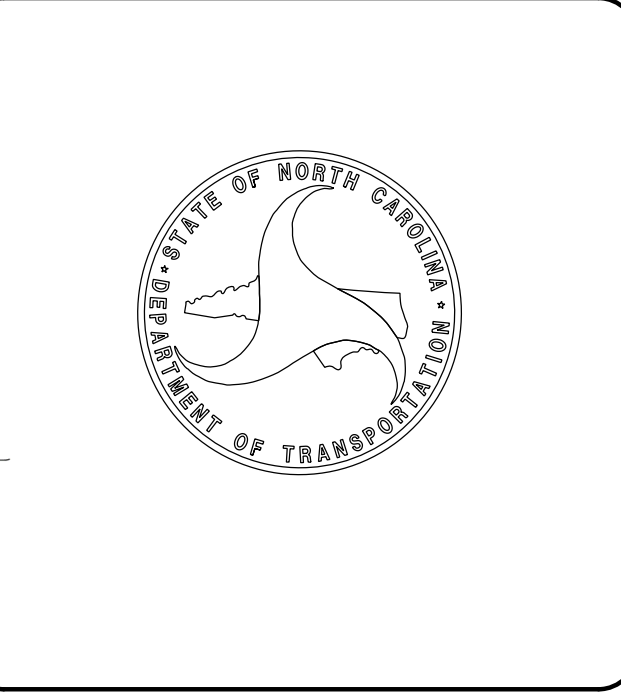

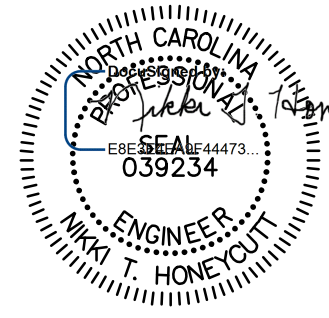

STV Engineers, Inc.
 800 West Trade St., Suite 715
 Charlotte, NC 28202
 NC License Number F-0991

PROJECT REFERENCE NO.	SHEET NO.
17BP.9.R.82	1A
RW SHEET NO.	ROADWAY DESIGN ENGINEER
	
DOCUMENT NOT CONSIDERED FINAL UNLESS ALL SIGNATURES COMPLETED	

INDEX OF SHEETS

SHEET NUMBER	SHEET
1	TITLE SHEET
1A	INDEX OF SHEETS, GENERAL NOTES, AND LIST OF STANDARD DRAWINGS
1B	CONVENTIONAL SYMBOLS
2A-1	PAVEMENT SCHEDULE AND TYPICAL SECTIONS
3B-1	EARTHWORK AND GUARDRAIL SUMMARY SHEET
4	PLAN AND PROFILE SHEET
RW-01 THRU RW-04	SURVEY CONTROL, EXISTING CENTERLINES, RIGHT OF WAY EASEMENT, AND PROPERTY TIES
TMP-1 THRU TMP-2	TRAFFIC MANAGEMENT PLANS
PMP-1	PAVEMENT MARKING PLANS
EC-1 THRU EC-5	EROSION CONTROL PLANS
UD-1 THRU UD-4	UTILITIES BY OTHERS PLANS
UC-1 THRU UC-5	UTILITY CONSTRUCTION PLANS
X-1 THRU X-5	CROSS-SECTIONS
C-1 THRU C-5	STRUCTURE PLANS
SN	STRUCTURE STANDARD NOTES

GENERAL NOTES

GENERAL NOTES: 2018 SPECIFICATIONS EFFECTIVE: 01-01-2018

GRADE LINE:
 GRADING AND SURFACING:

THE GRADE LINES SHOWN DENOTE THE FINISHED ELEVATION OF THE PROPOSED SURFACING AT GRADE POINTS SHOWN ON THE TYPICAL SECTIONS. GRADE LINES MAY BE ADJUSTED AT THEIR BEGINNING AND ENDING AND AT STRUCTURES AS DIRECTED BY THE ENGINEER IN ORDER TO SECURE A PROPER TIE-IN.

CLEARING:

CLEARING ON THIS PROJECT SHALL BE PERFORMED TO THE LIMITS ESTABLISHED BY METHOD II.

SUPERELEVATION:

ALL CURVES ON THIS PROJECT SHALL BE SUPERELEVATED IN ACCORDANCE WITH STD. NO. 225.04 USING THE RATE OF SUPERELEVATION AND RUNOFF SHOWN ON THE PLANS. SUPERELEVATION IS TO BE REVOLVED ABOUT THE GRADE POINTS SHOWN ON THE TYPICAL SECTIONS.

SHOULDER CONSTRUCTION:

ASPHALT, EARTH, AND CONCRETE SHOULDER CONSTRUCTION ON THE HIGH SIDE OF SUPERELEVATED CURVES SHALL BE IN ACCORDANCE WITH STD. NO. 560.01.

GUARDRAIL:

THE GUARDRAIL LOCATIONS SHOWN ON THE PLANS MAY BE ADJUSTED DURING CONSTRUCTION AS DIRECTED BY THE ENGINEER. THE CONTRACTOR SHOULD CONSULT WITH THE ENGINEER PRIOR TO ORDERING GUARDRAIL MATERIAL.

RIGHT-OF-WAY MARKERS:

ALL RIGHT-OF-WAY MARKERS ON THIS PROJECT SHALL BE PLACED BY THE CONTRACTOR.

STANDARD DRAWINGS

2018 ROADWAY ENGLISH STANDARD DRAWINGS EFF. January, 2018















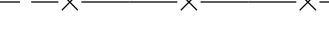

The following Roadway Standards as appear in "Roadway Standard Drawings" Highway Design Branch - N. C. Department of Transportation - Raleigh, N. C., Dated January, 2018 are applicable to this project and by reference hereby are considered a part of these plans:

STD.NO.	TITLE
DIVISION 2 - EARTHWORK	
200.03	Method of Clearing - Method II
225.02	Guide for Grading Subgrade - Secondary and Local
225.04	Method of Obtaining Superlevation - Two Lane Pavement
DIVISION 5 - SUBGRADE, BASES AND SHOULDERS	
560.01	Method of Shoulder Construction - High Side of Superelevated Curve - Method I
DIVISION 8 - INCIDENTALS	
862.01	Guardrail Placement
862.02	Guardrail Installation
DIVISION 11 - WORK ZONE TRAFFIC CONTROL	
1101.03	Temporary Road Closures
1110.01	Stationary Work Zone Signs - Mounting Height & Lateral Clearance
1145.01	Barricades - Type III
DIVISION 16 - EROSION CONTROL AND ROADSIDE DEVELOPMENT	
1605.01	Temporary Silt Fence
1607.01	Gravel Construction Entrance
1622.01	Guide For Temporary Berms And Slope Drains
1630.06	Special Stilling Basin
1631.01	Matting Installation
1632.03	Rock Inlet Sediment Trap Type C
1633.01	Temporary Rock Silt Check Type A
1633.02	Temporary Rock Silt Check Type B



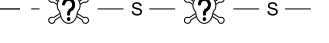





STATE OF NORTH CAROLINA, DIVISION OF HIGHWAYS CONVENTIONAL PLAN SHEET SYMBOLS

Note: Not to Scale





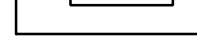
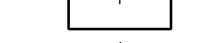
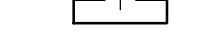

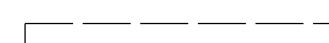

BOUNDARIES AND PROPERTY:

State Line	_____
County Line	_____
Township Line	_____
City Line	_____
Reservation Line	_____
Property Line	_____
Existing Iron Pin (EIP)	_____ 
Computed Property Corner	_____ 
Existing Concrete Monument (ECM)	_____ 
Parcel/Sequence Number	_____ 
Existing Fence Line	_____ 
Proposed Woven Wire Fence	_____ 
Proposed Chain Link Fence	_____ 
Proposed Barbed Wire Fence	_____ 
Existing Wetland Boundary	_____ 
Proposed Wetland Boundary	_____ 
Existing Endangered Animal Boundary	_____ 
Existing Endangered Plant Boundary	_____ 
Existing Historic Property Boundary	_____ 
Known Contamination Area: Soil	_____ 
Potential Contamination Area: Soil	_____ 
Known Contamination Area: Water	_____ 
Potential Contamination Area: Water	_____ 
Contaminated Site: Known or Potential	_____ 

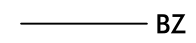
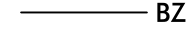
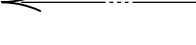
BUILDINGS AND OTHER CULTURE:

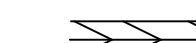
Gas Pump Vent or U/G Tank Cap	_____ 
Sign	_____ 
Well	_____ 
Small Mine	_____ 
Foundation	_____ 
Area Outline	_____ 
Cemetery	_____ 
Building	_____ 
School	_____ 
Church	_____ 
Dam	_____ 

























HYDROLOGY:

Stream or Body of Water	_____ 
Hydro, Pool or Reservoir	_____ 
Jurisdictional Stream	_____ 
Buffer Zone 1	_____ 
Buffer Zone 2	_____ 
Flow Arrow	_____ 
Disappearing Stream	_____ 
Spring	_____ 
Wetland	_____ 
Proposed Lateral, Tail, Head Ditch	_____ 
False Sump	_____ 









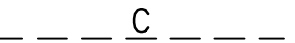
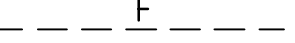

RAILROADS:

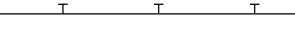
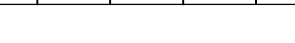

Standard Gauge	_____ 
RR Signal Milepost	_____ 
Switch	_____ 
RR Abandoned	_____ 
RR Dismantled	_____ 

RIGHT OF WAY & PROJECT CONTROL:







Primary Horiz Control Point	_____ 
Primary Horiz and Vert Control Point	_____ 
Secondary Horiz and Vert Control Point	_____ 
Vertical Benchmark	_____ 
Existing Right of Way Monument	_____ 
Proposed Right of Way Monument (Rebar and Cap)	_____ 
Proposed Right of Way Monument (Concrete)	_____ 
Existing Permanent Easement Monument	_____ 
Proposed Permanent Easement Monument (Rebar and Cap)	_____ 
Existing C/A Monument	_____ 
Proposed C/A Monument (Rebar and Cap)	_____ 
Proposed C/A Monument (Concrete)	_____ 
Existing Right of Way Line	_____ 
Proposed Right of Way Line	_____ 
Existing Control of Access Line	_____ 
Proposed Control of Access Line	_____ 
Proposed ROW and CA Line	_____ 
Existing Easement Line	_____ 
Proposed Temporary Construction Easement	_____ 
Proposed Temporary Drainage Easement	_____ 
Proposed Permanent Drainage Easement	_____ 
Proposed Permanent Drainage/Utility Easement	_____ 
Proposed Permanent Utility Easement	_____ 
Proposed Temporary Utility Easement	_____ 
Proposed Aerial Utility Easement	_____ 

ROADS AND RELATED FEATURES:

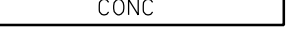
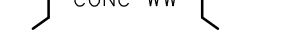
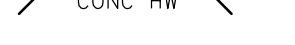
Existing Edge of Pavement	_____ 
Existing Curb	_____ 
Proposed Slope Stakes Cut	_____ 
Proposed Slope Stakes Fill	_____ 
Proposed Curb Ramp	_____ 
Existing Metal Guardrail	_____ 
Proposed Guardrail	_____ 
Existing Cable Guiderail	_____ 
Proposed Cable Guiderail	_____ 
Equality Symbol	_____ 
Pavement Removal	_____ 
VEGETATION:	
Single Tree	_____ 
Single Shrub	_____ 
Hedge	_____ 

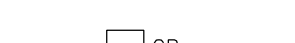











Woods Line	_____ 
Orchard	_____ 
Vineyard	_____ 

EXISTING STRUCTURES:

















MAJOR:	
Bridge, Tunnel or Box Culvert	_____ 
Bridge Wing Wall, Head Wall and End Wall	_____ 
MINOR:	
Head and End Wall	_____ 
Pipe Culvert	_____ 
Footbridge	_____ 
Drainage Box: Catch Basin, DI or JB	_____ 
Paved Ditch Gutter	_____ 
Storm Sewer Manhole	_____ 
Storm Sewer	_____ 

UTILITIES:



















* SUE - Subsurface Utility Engineering
LOS - Level of Service - A,B,C or D (Accuracy)

POWER:	
Existing Power Pole	_____ 
Proposed Power Pole	_____ 
Existing Joint Use Pole	_____ 
Proposed Joint Use Pole	_____ 
Power Manhole	_____ 
Power Line Tower	_____ 
Power Transformer	_____ 
U/G Power Cable Hand Hole	_____ 
H-Frame Pole	_____ 
U/G Power Line Test Hole (SUE - LOS A)*	_____ 
U/G Power Line (SUE - LOS B)*	_____ 
U/G Power Line (SUE - LOS C)*	_____ 
U/G Power Line (SUE - LOS D)*	_____ 







TELEPHONE:

Existing Telephone Pole	_____ 
Proposed Telephone Pole	_____ 
Telephone Manhole	_____ 
Telephone Pedestal	_____ 
Telephone Cell Tower	_____ 
U/G Telephone Cable Hand Hole	_____ 
U/G Telephone Test Hole (SUE - LOS A)*	_____ 
U/G Telephone Cable (SUE - LOS B)*	_____ 
U/G Telephone Cable (SUE - LOS C)*	_____ 
U/G Telephone Cable (SUE - LOS D)*	_____ 
U/G Telephone Conduit (SUE - LOS B)*	_____ 
U/G Telephone Conduit (SUE - LOS C)*	_____ 
U/G Telephone Conduit (SUE - LOS D)*	_____ 
U/G Fiber Optics Cable (SUE - LOS B)*	_____ 
U/G Fiber Optics Cable (SUE - LOS C)*	_____ 
U/G Fiber Optics Cable (SUE - LOS D)*	_____ 









WATER:

Water Manhole	_____ 
Water Meter	_____ 
Water Valve	_____ 
Water Hydrant	_____ 
U/G Water Line Test Hole (SUE - LOS A)*	_____ 
U/G Water Line (SUE - LOS B)*	_____ 
U/G Water Line (SUE - LOS C)*	_____ 
U/G Water Line (SUE - LOS D)*	_____ 
Above Ground Water Line	_____ 
TV:	
TV Pedestal	_____ 
TV Tower	_____ 
U/G TV Cable Hand Hole	_____ 
U/G TV Test Hole (SUE - LOS A)*	_____ 
U/G TV Cable (SUE - LOS B)*	_____ 
U/G TV Cable (SUE - LOS C)*	_____ 
U/G TV Cable (SUE - LOS D)*	_____ 
U/G Fiber Optic Cable (SUE - LOS B)*	_____ 
U/G Fiber Optic Cable (SUE - LOS C)*	_____ 
U/G Fiber Optic Cable (SUE - LOS D)*	_____ 











GAS:

Gas Valve	_____ 
Gas Meter	_____ 
U/G Gas Line Test Hole (SUE - LOS A)*	_____ 
U/G Gas Line (SUE - LOS B)*	_____ 
U/G Gas Line (SUE - LOS C)*	_____ 
U/G Gas Line (SUE - LOS D)*	_____ 
Above Ground Gas Line	_____ 

SANITARY SEWER:

Sanitary Sewer Manhole	_____ 
Sanitary Sewer Cleanout	_____ 
U/G Sanitary Sewer Line	_____ 
Above Ground Sanitary Sewer	_____ 
SS Force Main Line Test Hole (SUE - LOS A)*	_____ 
SS Force Main Line (SUE - LOS B)*	_____ 
SS Force Main Line (SUE - LOS C)*	_____ 
SS Force Main Line (SUE - LOS D)*	_____ 

MISCELLANEOUS:

Utility Pole	_____ 
Utility Pole with Base	_____ 
Utility Located Object	_____ 
Utility Traffic Signal Box	_____ 
Utility Unknown U/G Line (SUE - LOS B)*	_____ 
U/G Tank; Water, Gas, Oil	_____ 
Underground Storage Tank, Approx. Loc.	_____ 
A/G Tank; Water, Gas, Oil	_____ 
Geoenvironmental Boring	_____ 
Abandoned According to Utility Records	_____ 
End of Information	_____ 

9/10/2021
3/31/2022
R:\Roadway\Proj\N\SH\T\17BP9R82_rdy_psn01B.dgn
SaucierSL

PAVEMENT SCHEDULE	
C1	PROP. APPROX. 3.0" ASPHALT CONCRETE SURFACE COURSE, TYPE S9.5B, AT AN AVERAGE RATE OF 168 LBS. PER SQ. YD. IN EACH OF TWO LAYERS.
C2	PROP. VAR. DEPTH ASPHALT CONCRETE SURFACE COURSE, TYPE S9.5B, AT AN AVERAGE RATE OF 112 LBS. PER SQ. YD. PER 1.0" DEPTH. TO BE PLACED IN LAYERS NOT LESS THAN 1.5" IN DEPTH OR GREATER THAN 2.0" IN DEPTH.
D1	PROP. APPROX. 4.0" ASPHALT CONCRETE INTERMEDIATE COURSE, TYPE I19.0C, AT AN AVERAGE RATE OF 456 LBS. PER SQ. YD.
D2	PROP. VAR. DEPTH ASPHALT CONCRETE INTERMEDIATE COURSE, TYPE I19.0C, AT AN AVERAGE RATE OF 114 LBS. PER SQ. YD. PER 1.0" DEPTH. TO BE PLACED IN LAYERS NOT LESS THAN 2.5" IN DEPTH OR GREATER THAN 4.0" IN DEPTH.
E1	PROP. APPROX. 4.0" ASPHALT CONCRETE BASE COURSE, TYPE B25.0C, AT AN AVERAGE RATE OF 456 LBS. PER SQ. YD.
E2	PROP. VAR. DEPTH ASPHALT CONCRETE BASE COURSE, TYPE B25.0C, AT AN AVERAGE RATE OF 114 LBS. PER SQ. YD. PER 1.0" DEPTH. TO BE PLACED IN LAYERS NOT LESS THAN 3.0" IN DEPTH OR GREATER THAN 5.5" IN DEPTH.
T	EARTH MATERIAL
U	EXISTING PAVEMENT
V	INCIDENTAL MILLING
W	PAVEMENT WEDGING

ALL PAVEMENT SLOPES ARE 1:1 UNLESS SHOWN OTHERWISE.

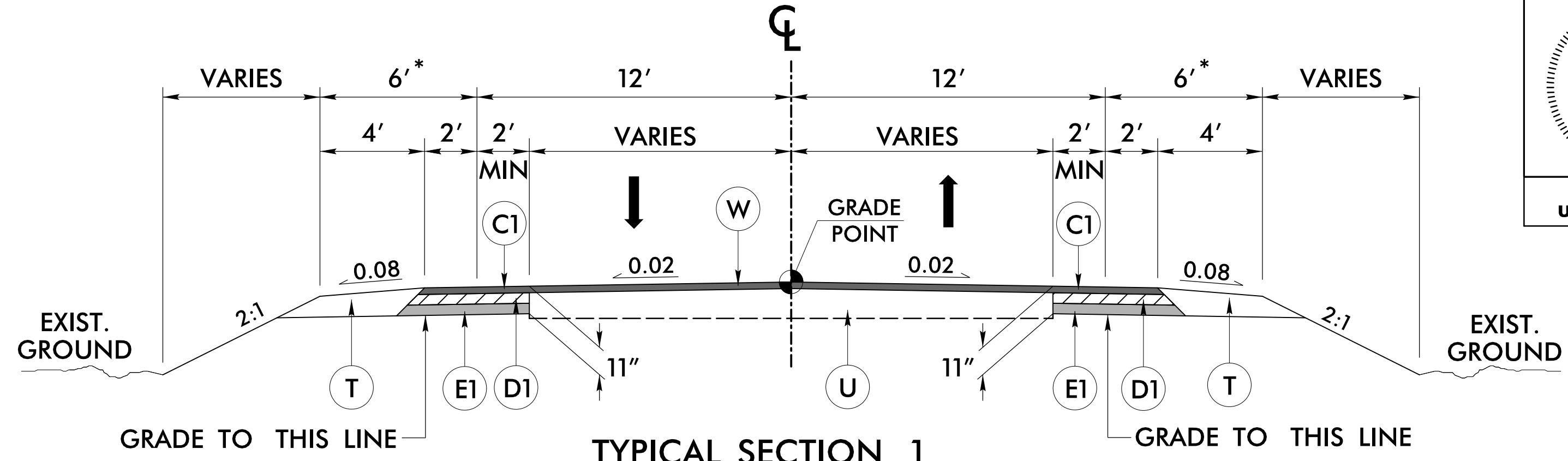

TYPICAL SECTION 1
 -L- STA. 13+60.00 TO 14+70.00
 -L- STA. 16+35.00 TO 16+60.00
 *9' MIN. WITH GUARDRAIL

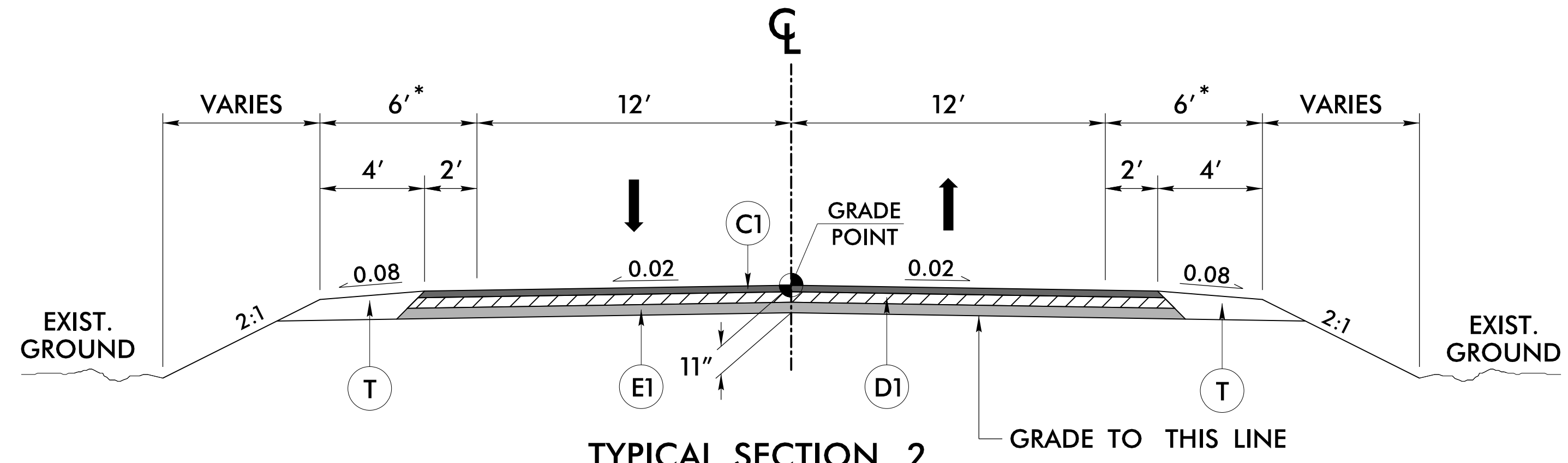

TYPICAL SECTION 2
 -L- STA. 14+70.00 TO 15+02.00 (BEGIN CULVERT)
 -L- STA. 15+38.00 (END CULVERT) TO 16+35.00
 *9' MIN. WITH GUARDRAIL

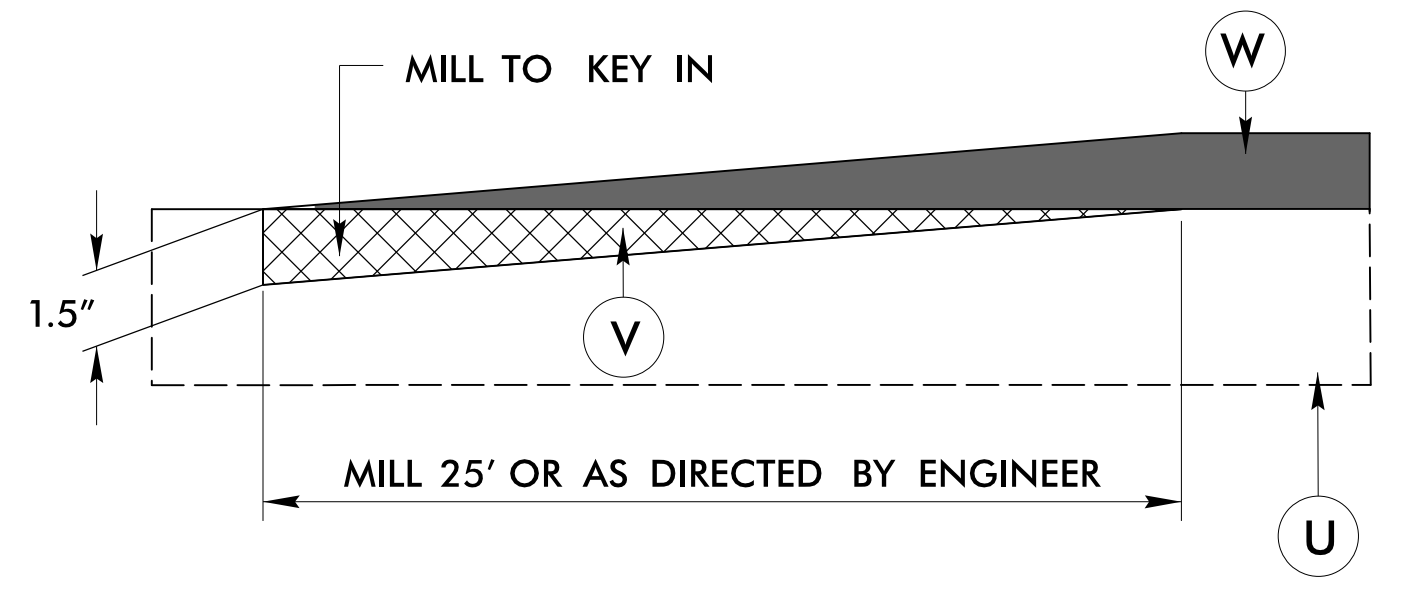

INCIDENTAL MILLING DETAIL
 -L- STA. 13+60.00 TO 13+85.00
 -L- STA. 16+35.00 TO 16+60.00

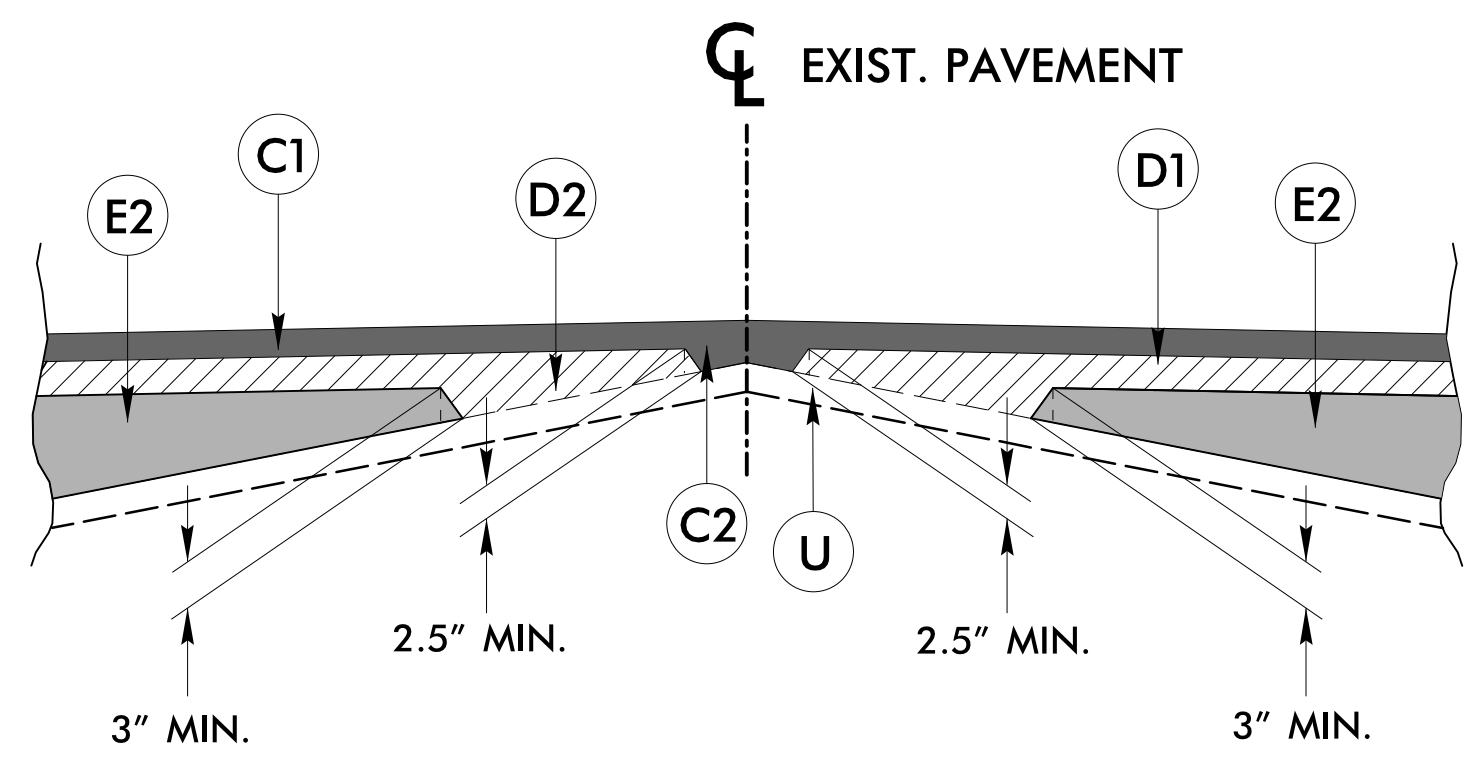

WEDGING DETAIL B

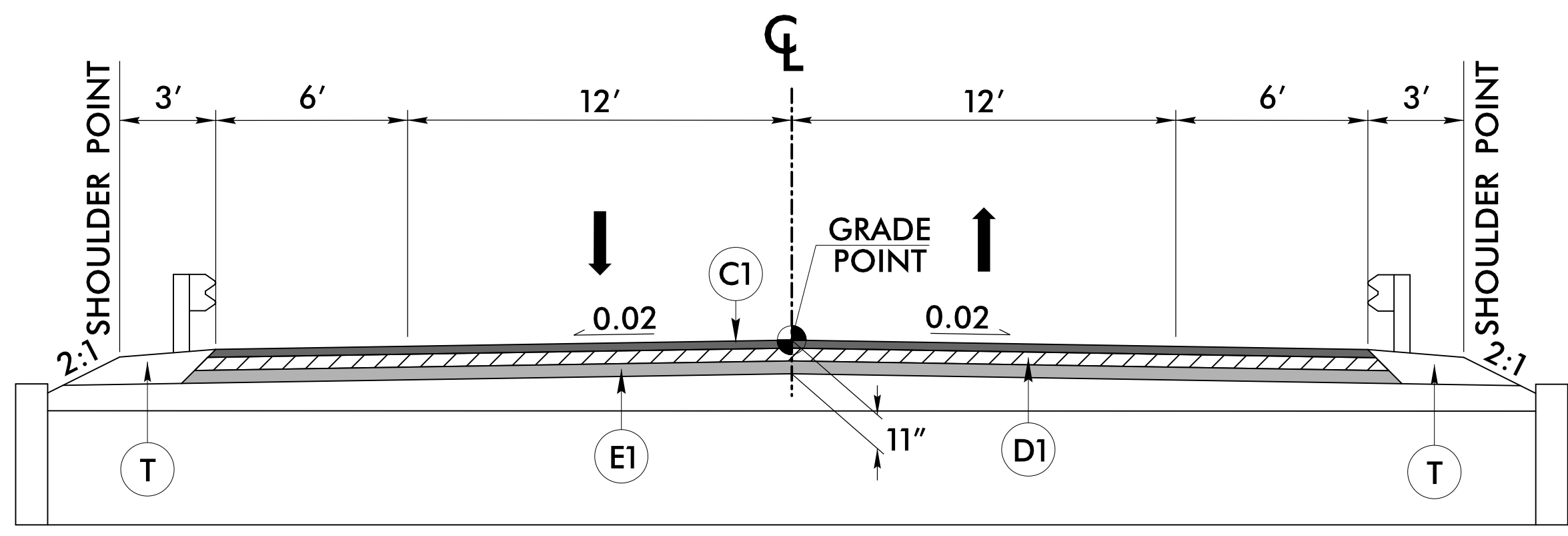

TYPICAL SECTION 3
 -L- STA. 15+02.00 (BEGIN CULVERT) TO 15+38.00 (END CULVERT)

8/17/19

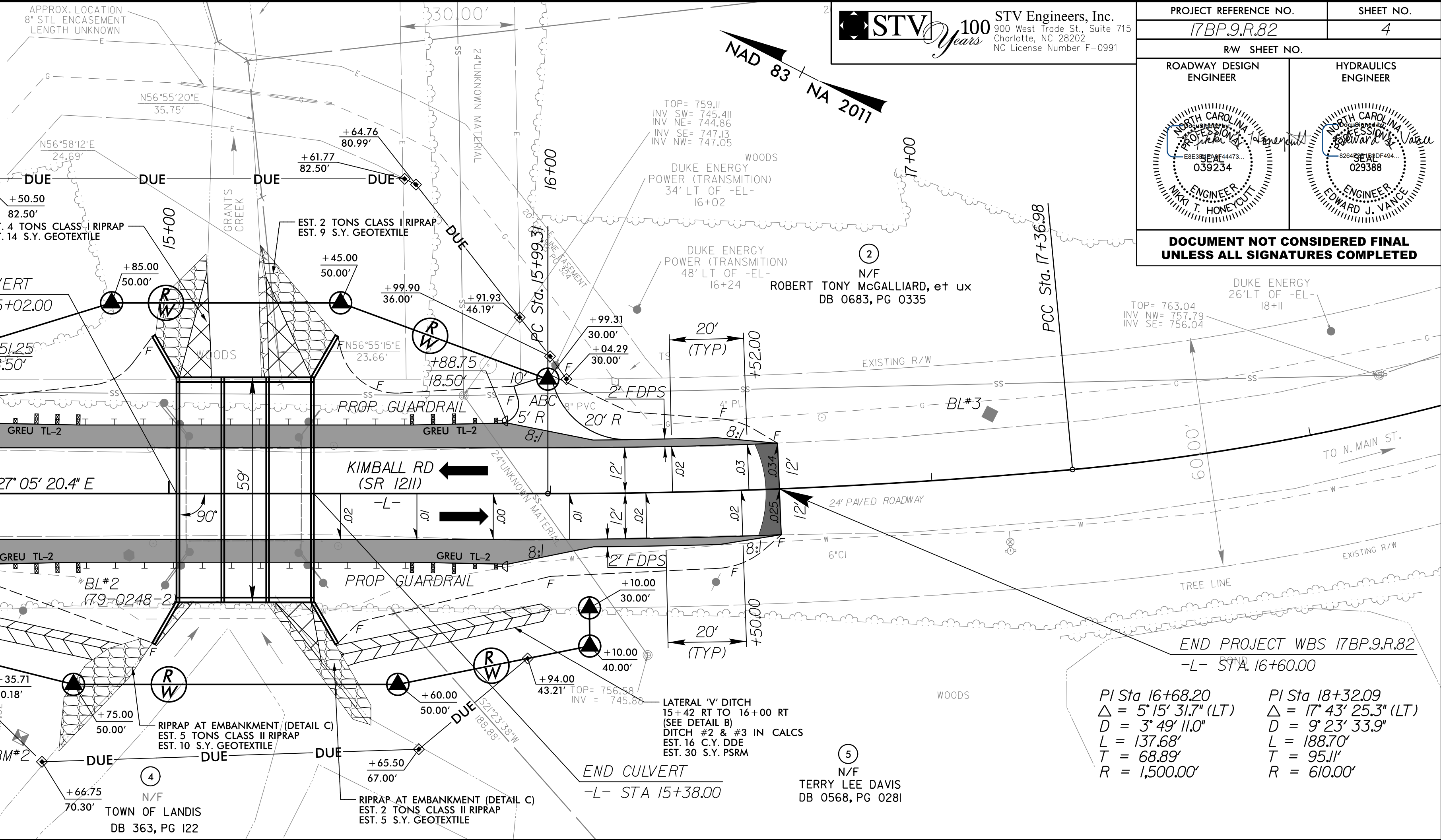
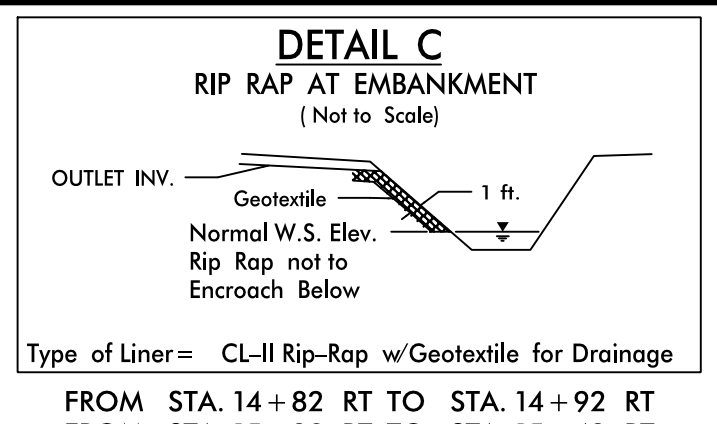
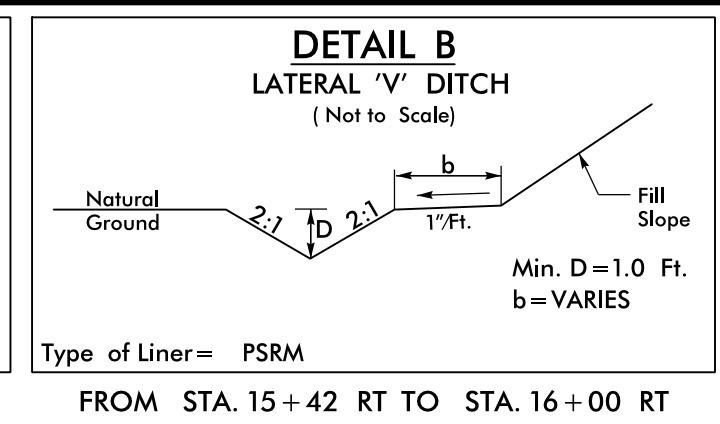
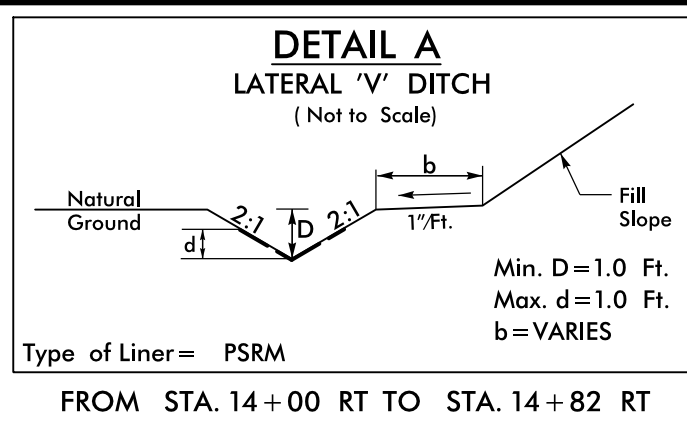

PROJECT REFERENCE NO. 17BP.9.R.82	SHEET NO. 4
RW SHEET NO.	HYDRAULICS ENGINEER
ROADWAY DESIGN ENGINEER	ENGINEER
DOCUMENT NOT CONSIDERED FINAL UNLESS ALL SIGNATURES COMPLETED	

PI Sta 12+03.61
 $\Delta = 3' 54' 09.3''$ (LT)
 $D = 1' 14' 53.8''$
 $L = 312.64'$
 $T = 156.38'$
 $R = 4,590.00'$

NOTE: INCIDENTAL MILL APPROXIMATELY 25' AT EACH TIE IN TO PROVIDE A SMOOTH TRANSITION TO THE EXISTING PAVEMENT

PI Sta 16+68.20
 $\Delta = 5' 15' 31.7''$ (LT)
 $D = 3' 49' 11.0''$
 $L = 137.68'$
 $T = 68.89'$
 $R = 1,500.00'$

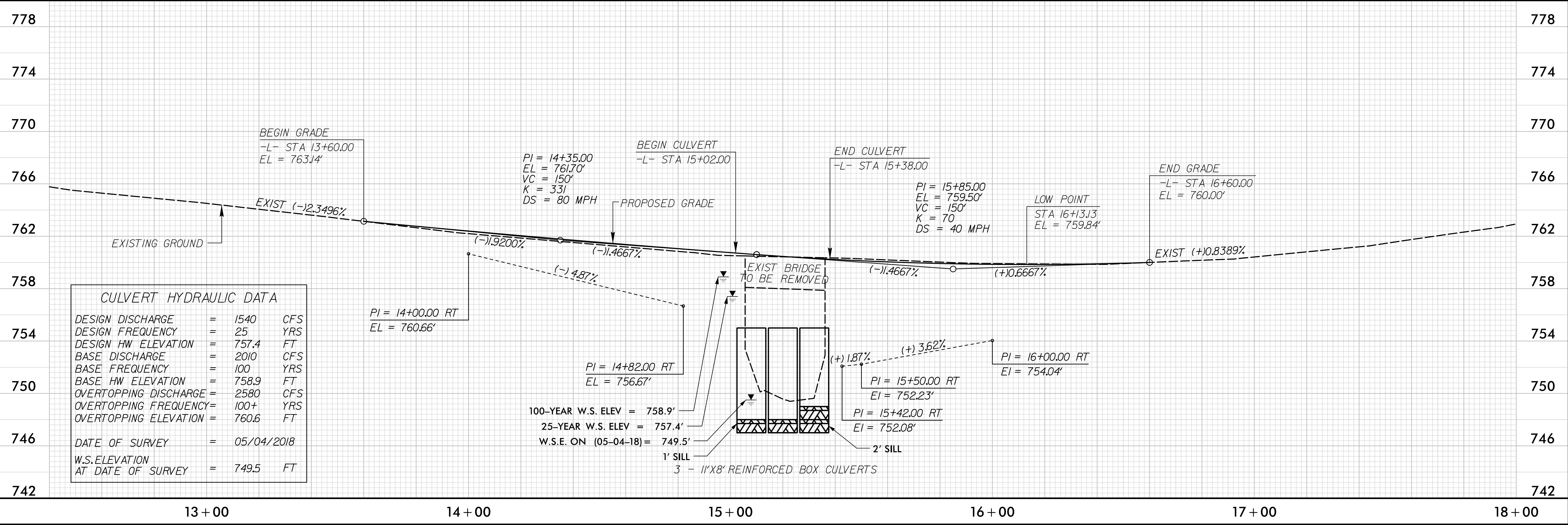

8/14/2022
 R:\17\2022\17BP.9.R.82\17BP.9.R.82_rdy_psh04.dgn
 Sources:

STATE	STATE PROJECT REFERENCE NO.	SHEET NO.	TOTAL SHEETS
N.C.	17BP.9.R.82	RW01	4

STATE OF NORTH CAROLINA
DIVISION OF HIGHWAYS

SURVEY CONTROL, EXISTING CENTERLINES,
RIGHT OF WAY, EASEMENTS AND PROPERTY TIES

ROWAN COUNTY

09/08/99
TIP PROJECT: 17BP.9.R.82

24-JAN-2022 07:30
S:\Units\Div09\Winston\Bridges\Division\LowImpact\79-0248-Kimball Rd\RW Staking\ToBeChecked\79-0248_Is_r_w01.dgn
mmotsinger AT LS-312635

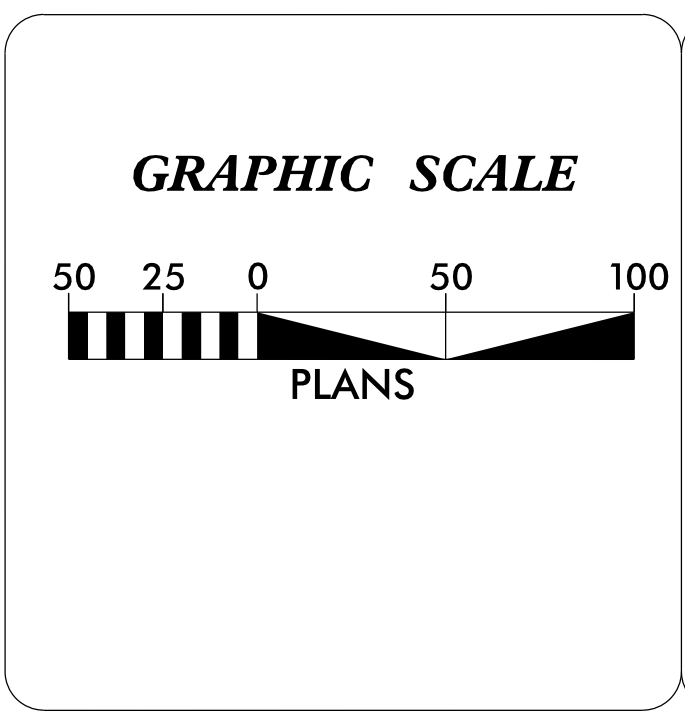
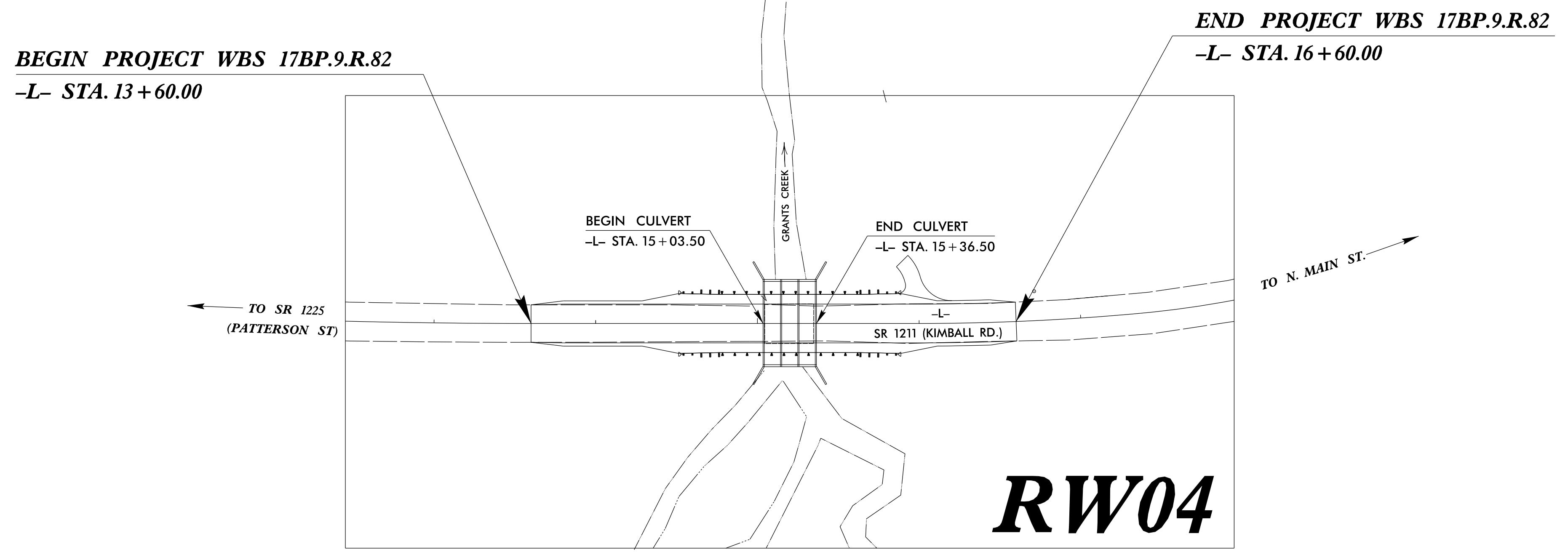
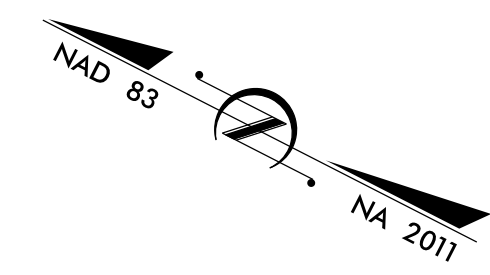

DATUM DESCRIPTION

THE LOCALIZED COORDINATE SYSTEM DEVELOPED FOR THIS PROJECT IS BASED ON THE STATE PLANE COORDINATES ESTABLISHED BY NCDOT FOR MONUMENT "79-0248-2" WITH NAD 83/NSRS 2007 STATE PLANE GRID COORDINATES OF NORTHING: 664,167.1180(ft) EASTING: 1,523,754.3300(ft) ELEVATION: 760.02(ft)

THE AVERAGE COMBINED GRID FACTOR USED ON THIS PROJECT (GROUND TO GRID) IS: 0.999856017

THE N.C. LAMBERT GRID BEARING AND LOCALIZED HORIZONTAL GROUND DISTANCE FROM "79-0248-2" TO -L- STATION 10+00.00 IS N 23°34'35.31" W 490.11(ft)

ALL LINEAR DIMENSIONS ARE LOCALIZED HORIZONTAL DISTANCES VERTICAL DATUM USED IS NAVD 88

Prepared in the Office of:

2018 STANDARD SPECIFICATIONS

RIGHT OF WAY DATE: XXXX/XXXX	LETTING DATE: XXXX/XXXX
--	-----------------------------------

PROFESSIONAL LAND SURVEYOR

DocuSigned by:
Michael L. Molsinger
F0B8F7E2E23C40E
SIGNATURE: _____

Date: 01/24/2022

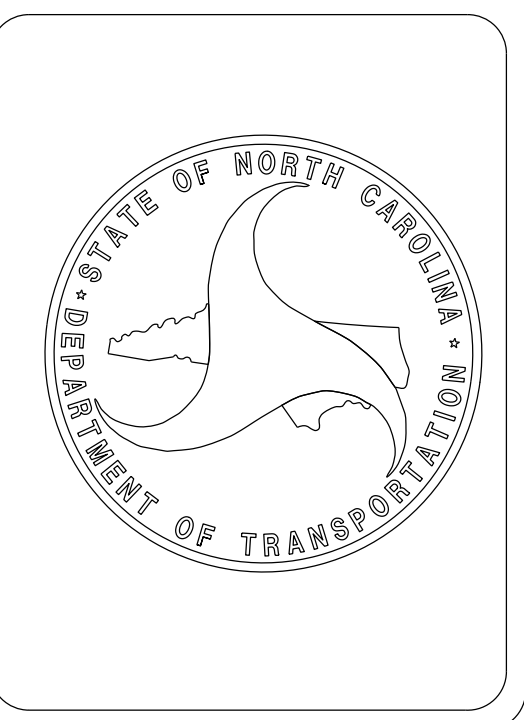

SURVEY CONTROL SHEET

W/ EXISTING CENTERLINE ALIGNMENTS PRIOR TO CONSTRUCTION

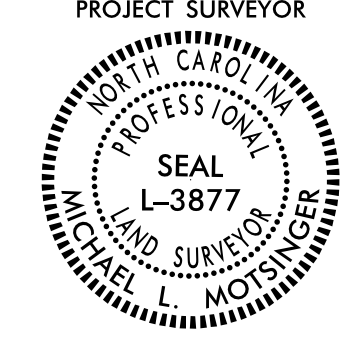
PROJECT REFERENCE NO. 79-0248	SHEET NO. RW02C-1
Location and Surveys	
INSERT CONSULTANT'S NAME	
PROJECT SURVEYOR 	
DOCUMENT NOT CONSIDERED FINAL UNLESS ALL SIGNATURES COMPLETED	

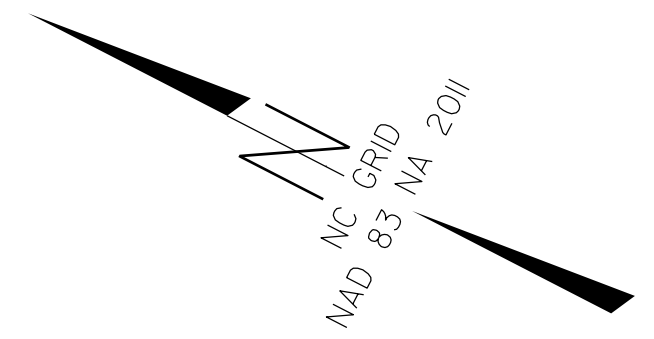

SEE SHEET RW02C-2
FOR FURTHER
ALIGNMENT DETAILS

I, Michael L. Motsinger, PLS, certify that the Project Control was performed under my supervision from an actual GPS survey made under my supervision and the following information was used to perform the survey:

Class of survey: **AA**
 Type of GPS field procedure: Opus
 Dates of survey: 05-05-2017
 Datum/Epoch: NAD 83/2011
 Published/Fixed-control use: [Project Control if applicable, N/A for RTN]
 Localized around: 790248-2
 Northing: 664167.1180
 Easting: 1523754.3300
 Combined grid factor: 0.999856017
 Geoid model: G12BNC
 Units: English

I also certify that the Baseline Control for this project was verified under my direct and responsible charge from an actual survey made under my supervision; that all horizontal closures had a minimum ratio of precision of 1:20,000 (Class AA) and Vertical accuracy to Class A. Field work was performed from June 2017 to July 2017, and all coordinates are based on NAD 83/2011 and all elevations are based on NAVD 88; that this survey was performed to meet the requirements of 21NCAC 56.1600 as applicable.

This 24th day of January, 2022.

DocuSigned by:

 Professional Land Surveyor L-3877

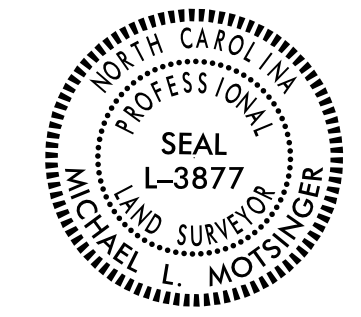

NOTES:

1. PROJECT CONTROL WAS ESTABLISHED USING GNSS, THE GLOBAL NAVIGATION SATELLITE SYSTEM.
2. THE SURVEY CONTROL DATA FOR THIS PROJECT HAS BEEN COMPILED FROM VARIOUS SOURCES. IF FURTHER INFORMATION REGARDING PROJECT CONTROL IS NEEDED, PLEASE CONTACT THE LOCATION AND SURVEYS UNIT.

SURVEY CONTROL SHEET

BASELINE AND BENCHMARKS

BL	POINT	DESC.	NORTH	EAST	ELEVATION
1	79-0248-1	GPS-1	664675.2960	1523514.0750	778.02
2	79-0248-2	GPS-2	664167.1180	1523754.3300	760.02
3		BL-3	663983.1820	1523890.0480	759.75
4		BL-4	663841.4950	1523958.5830	766.44
5		BL-5	663722.5340	1524096.8750	774.72

.....
 BM-1 ELEVATION = 773.92
 N 664618 E 1523533
 X SCRIBED IN IN TOP OF PIPE

.....
 BM-2 ELEVATION = 759.96
 N 664171 E 1523699
 R/R SPIKE IN 18" OAK

PROJECT REFERENCE NO. 79-0248	SHEET NO. RW02C-2
Location and Surveys	
	
DOCUMENT NOT CONSIDERED FINAL UNLESS ALL SIGNATURES COMPLETED	

I, Michael L. Motsinger, PLS, certify that the Project Control was performed under my supervision from an actual GPS survey made under my supervision and the following information was used to perform the survey:

Class of survey: **AA**
 Type of GPS field procedure: Opus
 Dates of survey: 05-05-2017
 Datum/Epoch: NAD 83/2011
 Published/Fixed-control use: [Project Control if applicable, N/A for RTN]
 Localized around: 790248-2
 Northing: 664167.1180
 Easting: 1523754.3300
 Combined grid factor: 0.999856017
 Geoid model: G12BNC
 Units: English

I also certify that the Baseline Control for this project was verified under my direct and responsible charge from an actual survey made under my supervision; that all horizontal closures had a minimum ratio of precision of 1:20,000 (Class AA) and Vertical accuracy to Class A. Field work was performed from June 2017 to July 2017, and all coordinates are based on NAD 83/2011 and all elevations are based on NAVD 88; that this survey was performed to meet the requirements of 21NCAC 56.1600 as applicable.

This 24th day of January, 2022.

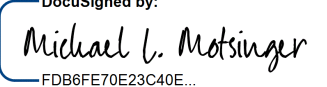
DocuSigned by:

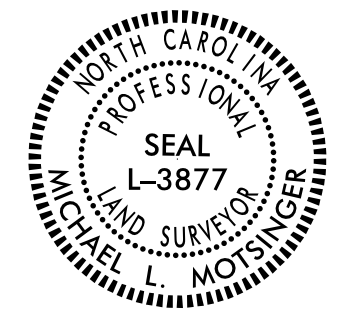
 Professional Land Surveyor L-3877



SURVEY CONTROL SHEET

W/ EXISTING CENTERLINE ALIGNMENTS PRIOR TO CONSTRUCTION

EL	POINT	N	E	BEARING	DIST	DELTA	D	L	T	R
	POT	664616.319	1523558.299							
	LINE			S 23°11'11.1" E	50.15					
	PC	664570.216	1523578.045							
	CURVE			S 24°44'53.8" E	241.33	03°07'25.2"(LT)	01°17'39.0"	241.36	120.71	4427.20
	PCC	664351.047	1523679.076							
	CURVE			S 26°41'58.4" E	86.48	00°46'44.1"(LT)	00°54'02.4"	86.48	43.24	6361.58
	PT	664273.786	1523717.933							
	LINE			S 27°05'20.4" E	221.02					
	PC	664077.013	1523818.579							
	CURVE			S 29°42'55.1" E	138.04	05°15'09.4"(LT)	03°48'13.6"	138.09	69.09	1506.29
	PCC	663957.125	1523887.005							
	CURVE			S 41°12'23.6" E	187.63	17°43'47.6"(LT)	09°24'42.2"	188.38	94.95	608.77
	PT	663815.963	1524010.611							
	LINE			S 50°04'17.4" E	124.62					
	POT	663735.978	1524106.176							

PROPOSED ALIGNMENT

		L	EAST
	POT	10+00.00	664616.3190
	PC	10+47.23	664572.9003
	PT	13+59.87	664289.9265
	PC	15+99.31	664076.7559
	PCC	17+36.98	663957.2309
	PT	19+25.68	663815.8399
	POT	20+50.11	663735.9778

NOTES:

1. PROJECT CONTROL WAS ESTABLISHED USING GNSS, THE GLOBAL NAVIGATION SATELLITE SYSTEM.
2. THE SURVEY CONTROL DATA FOR THIS PROJECT HAS BEEN COMPILED FROM VARIOUS SOURCES. IF FURTHER INFORMATION REGARDING PROJECT CONTROL IS NEEDED, PLEASE CONTACT THE LOCATION AND SURVEYS UNIT.

REVISIONS

24-JAN-2022 08:48
 S:\Units\Div\08\Winston\Rights Computer\Bridges\Division\LowImpact\79-0248-Kimball Rd\RW Staking\to be checked\790248.LS-rw02c-2.dgn
 M.L. Motsinger

6/2/19

PROJECT REFERENCE NO. 79-0248	SHEET NO. RW04
Location and Surveys	
INSERT CONSULTANT'S NAME	
PROJECT SURVEYOR	
	
DOCUMENT NOT CONSIDERED FINAL UNLESS ALL SIGNATURES COMPLETED	

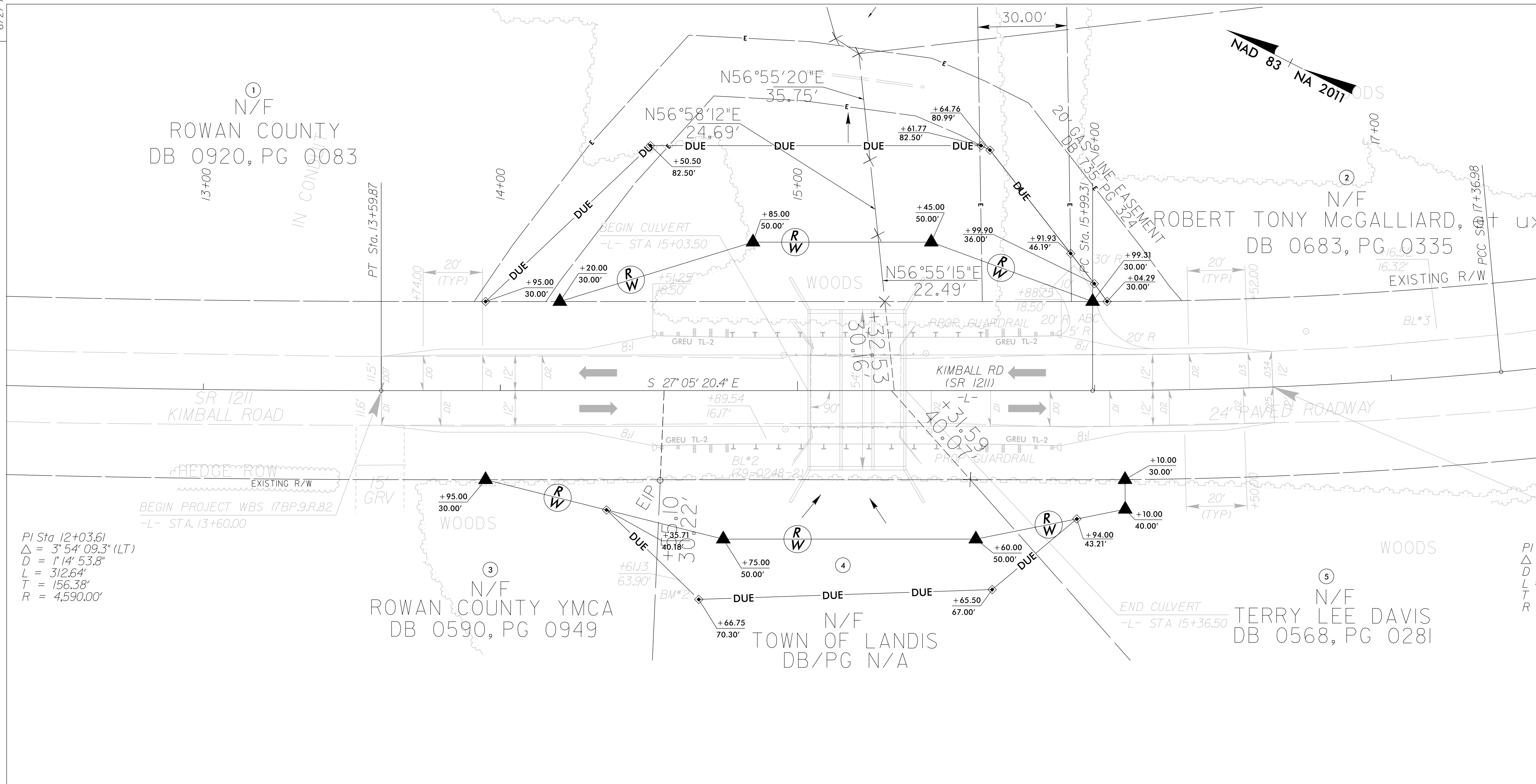

PI Sta 12+03.61
 $\Delta = 3^\circ 54' 09.3''$ (LT)
 $D = 1^\circ 14' 53.8''$
 $L = 312.64'$
 $T = 156.38'$
 $R = 4,590.00'$

PI Sta 16+68.20
 $\Delta = 5^\circ 15' 31.7''$ (LT)
 $D = 3^\circ 49' 11.0''$
 $L = 137.68'$
 $T = 68.89'$
 $R = 1,500.00'$

PI Sta 18+32.09
 $\Delta = 17^\circ 43' 25.3''$ (LT)
 $D = 9^\circ 23' 33.9''$
 $L = 188.70'$
 $T = 95.11'$
 $R = 610.00'$

ROW MARKER IRON PIN AND CAP-E

ALIGN	STATION	OFFSET	NORTH	EAST
L	13+95.00	30.00	664244.9913	1523698.9646
L	14+20.00	-30.00	664250.0563	1523763.7669
L	14+75.00	50.00	664164.6598	1523717.5885
L	14+85.00	-50.00	664201.2942	1523811.1723
L	15+45.00	-50.00	664147.8762	1523838.4947
L	15+60.00	50.00	664088.9843	1523756.2953
L	15+99.31	-30.00	664090.4172	1523845.4198
L	16+10.00	30.00	664053.4051	1523797.0036
L	16+10.00	40.00	664048.7871	1523788.1316

ROW MARKER PERMANENT EASEMENT-E

ALIGN	STATION	OFFSET	NORTH	EAST
L	13+95.00	-30.00	664272.3138	1523752.3826
L	14+35.71	40.18	664204.1104	1523708.4424
L	14+50.50	-82.50	664246.8093	1523824.3966
L	14+66.75	70.30	664162.7653	1523695.7601
L	15+61.77	-82.50	664147.7472	1523875.0653
L	15+64.76	-80.99	664144.4001	1523875.0835
L	15+65.50	67.00	664076.3463	1523743.6648
L	15+91.93	-46.19	664104.3594	1523856.4716
L	15+94.00	43.21	664061.8051	1523777.8213
L	15+99.90	-36.00	664092.6338	1523851.0213
L	16+04.29	-30.00	664086.0796	1523847.6485

I, Michael L. Motsinger, certify that the right of way and permanent easement monumentation for this project shown herein was completed under my direct and responsible charge from an actual survey made under my supervision; that all horizontal closures had a minimum ratio of precision of 1:10,000 (Class A). Field work was performed from November 2021 to December 2021, and all coordinates are based on NAD83/2011; That this survey was performed to meet the requirements of 21NCAC 56.1600 as applicable.

This 24th day of January, 2022.

DocuSigned by:
 Michael L. Motsinger
 FDB8FE70E23CAE...

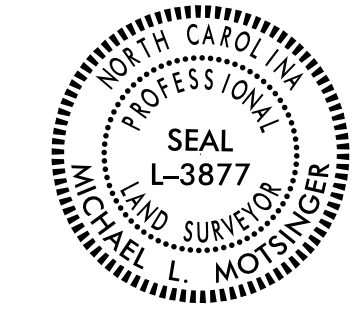

Professional Land Surveyor L-3877

NOTES:

1. IF FURTHER INFORMATION REGARDING PROJECT CONTROL IS NEEDED PLEASE CONTACT THE LOCATION AND SURVEYS UNIT.
2. PROJECT CONTROL WAS ESTABLISHED USING GNSS, THE GLOBAL NAVIGATION SATELLITE SYSTEM.
3. RIGHT OF WAY MONUMENTATION ESTABLISHED ____ TO ____.

REVISIONS

24-JAN-2022 08:45
 S:\Units\2022\08\Winston\Bridges\Division\LowImpact\79-0248_Kimball1.Rd\RW Staking\to be checked\790248_1s_RW04.dgn
 M.L.Motsinger

OFF-SITE DETOUR SIGNING AND ROAD CLOSURE SIGNING

PROJECT REFERENCE NO. 17BP9.R.82	SHEET NO. TMP-1
RW SHEET NO.	
 STV Engineers, Inc. 900 West Trade St., Suite 715 Charlotte, NC 28202 NC License Number F-0991	
DOCUMENT NOT CONSIDERED FINAL UNLESS ALL SIGNATURES COMPLETED	

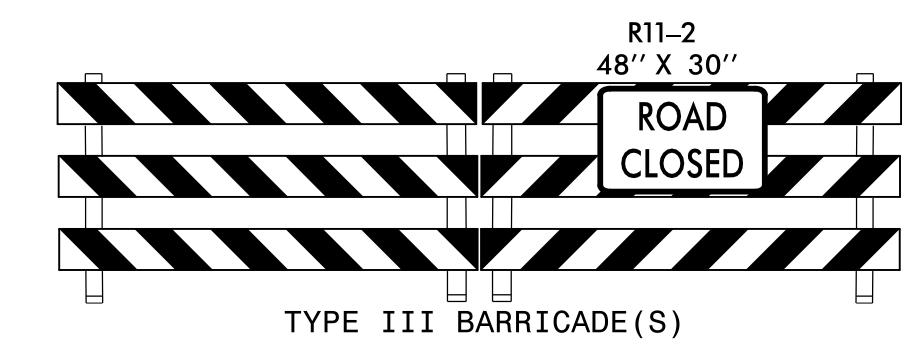
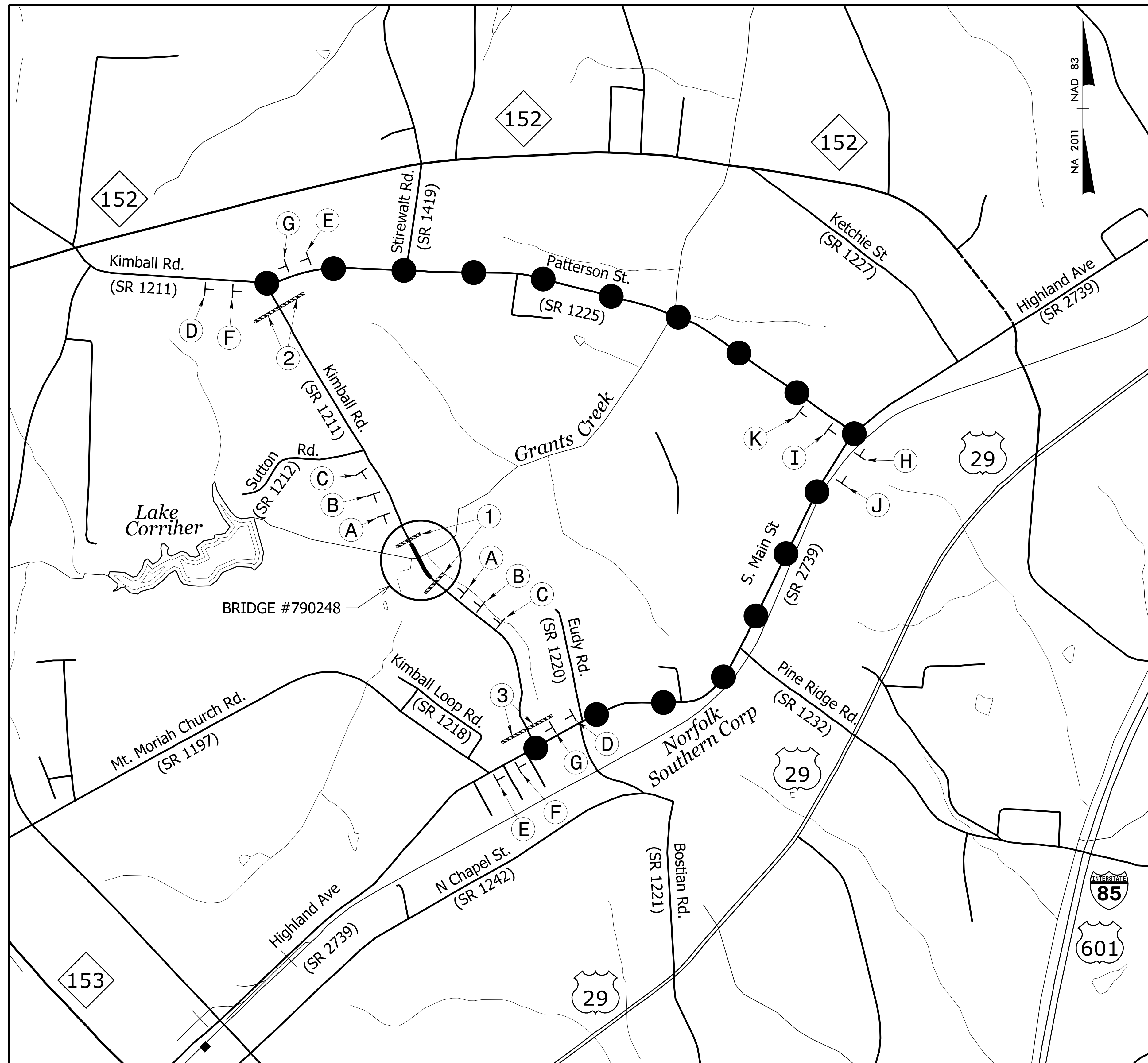

1

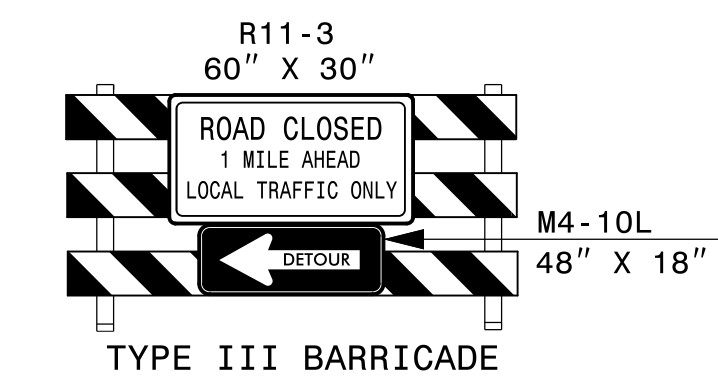

2

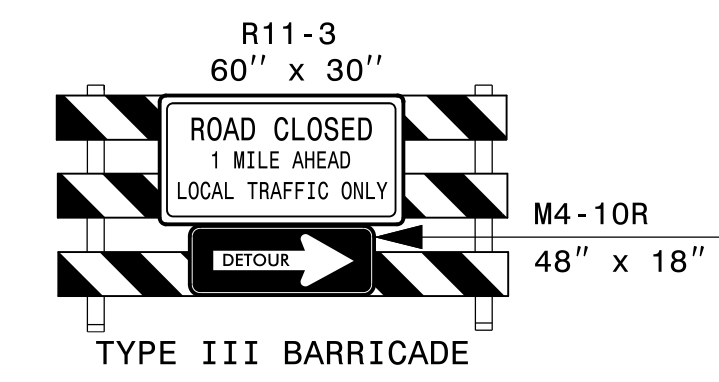

3

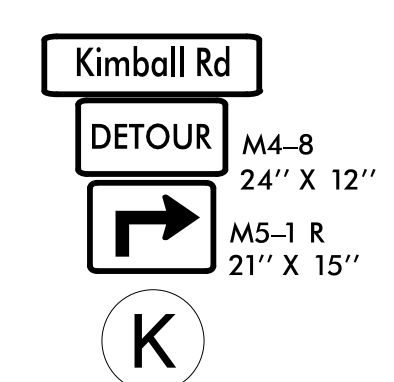
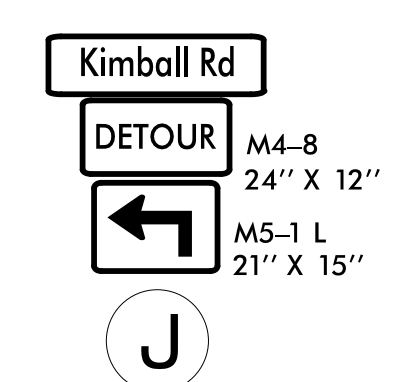
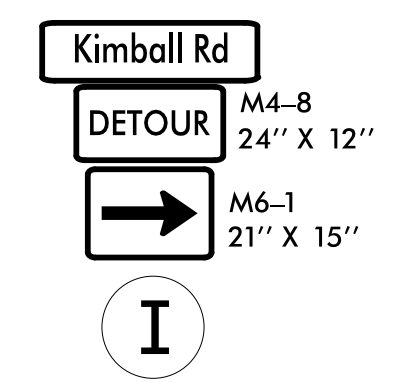
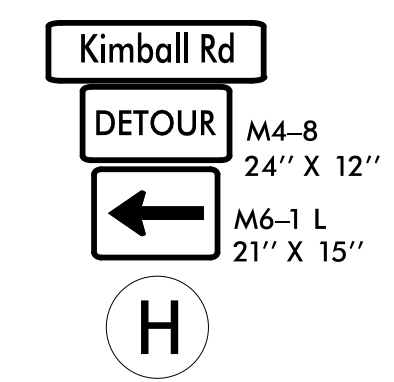
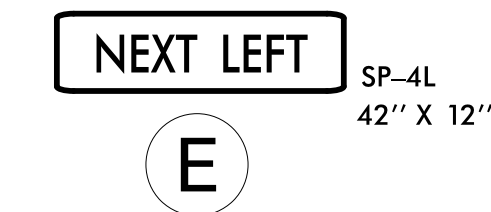
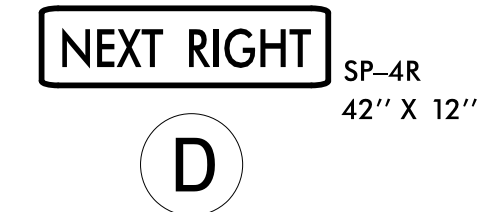
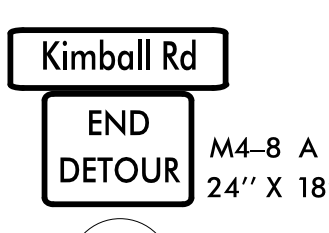
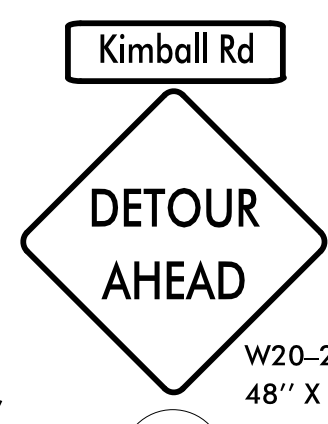
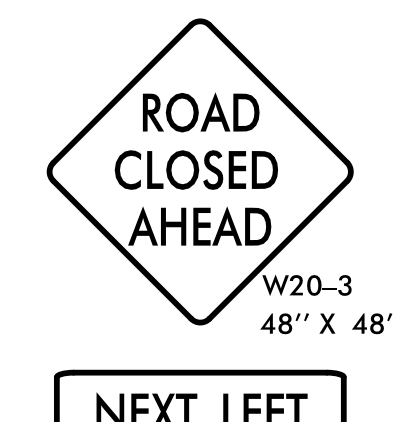
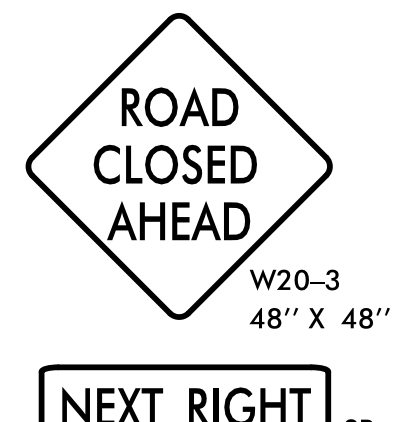
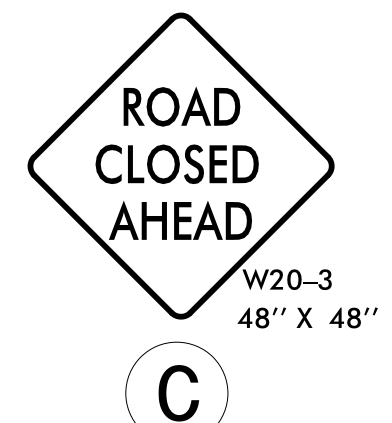
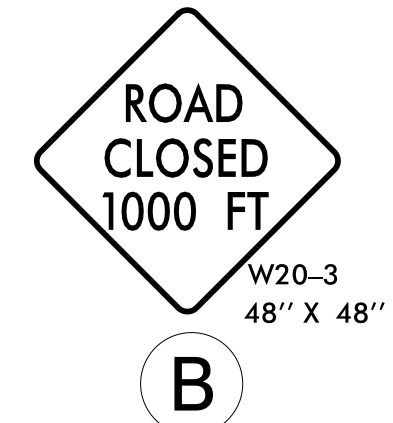
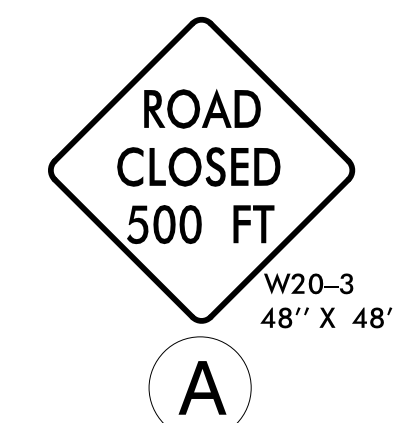

SEE ROADWAY STD DWG 1101.03, SHEET 1 OF 9 FOR ADVANCE WARNING AND BARRICADE PLACEMENT.

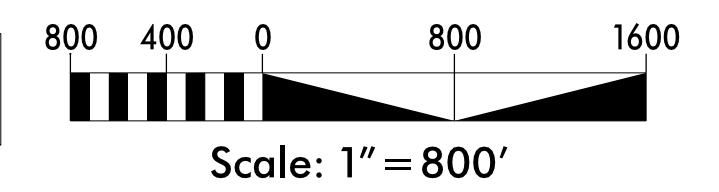

4/18/2022
C:\Users\jtr\Documents\Traffic\TrafficControl\17BP9.R.82_rdy_tmp01.dgn
SoucieSL

ROADWAY STANDARD DRAWINGS

THE FOLLOWING ROADWAY STANDARDS AS SHOWN IN "ROADWAY STANDARD DRAWINGS" - PROJECT SERVICES UNIT - N.C. DEPARTMENT OF TRANSPORTATION - RALEIGH, N.C., DATED JANUARY 2018 ARE APPLICABLE TO THIS PROJECT AND BY REFERENCE HEREBY ARE CONSIDERED A PART OF THESE PLANS:

STD. NO.	TITLE
1205.01	PAVEMENT MARKINGS - LINE TYPES AND OFFSETS
1205.02	PAVEMENT MARKINGS - TWO-LANE AND MULTILANE ROADWAYS
1261.01	GUARDRAIL AND BARRIER DELINEATORS - INSTALLATION SPACING
1261.02	GUARDRAIL AND BARRIER DELINEATORS - TYPES AND MOUNTING
1262.01	GUARDRAIL END DELINEATION

GENERAL NOTES

THE FOLLOWING GENERAL NOTES APPLY AT ALL TIMES FOR THE DURATION OF THE CONSTRUCTION PROJECT, EXCEPT WHEN OTHERWISE NOTED IN THE PLAN, OR DIRECTED BY THE ENGINEER.

- A) INSTALL PAVEMENT MARKINGS ON THE FINAL SURFACE.
- B) TIE PROPOSED PAVEMENT MARKING LINES TO EXISTING PAVEMENT MARKING LINES.
- C) REMOVE/REPLACE ANY CONFLICTING/DAMAGED PAVEMENT MARKINGS AND MARKERS.
- D) PASSING ZONES WILL BE DETERMINED IN THE FIELD AND MUST BE APPROVED BY THE ENGINEER.
- E) REPLACE ANY PAVEMENT MARKINGS BEYOND THE PROJECT LIMITS DAMAGED BY THE CONTRACTORS' OPERATIONS DURING CONSTRUCTION.

ROAD NAME	MARKING
SR 1211 (KIMBALL RD)	THERMO

STV 100 Years
 STV Engineers, Inc.
 900 West Trade St., Suite 715
 Charlotte, NC 28202
 NC License Number F-0991

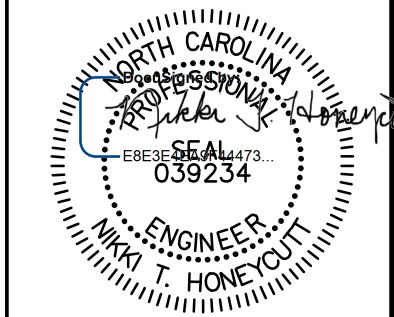
PROJECT REFERENCE NO. 17BP.9.R.82	SHEET NO. PMP-1
RW SHEET NO.	
ROADWAY DESIGN ENGINEER	
	
DOCUMENT NOT CONSIDERED FINAL UNLESS ALL SIGNATURES COMPLETED	

PAVEMENT MARKING SCHEDULE
T1 - THERMOPLASTIC - WHITE EDGELINE (4" 90MIL)
T13 - THERMOPLASTIC - YELLOW DOUBLE CENTER LINE (4" 90MIL)

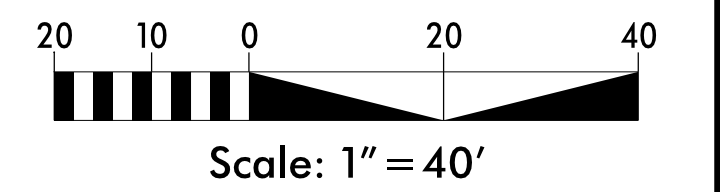
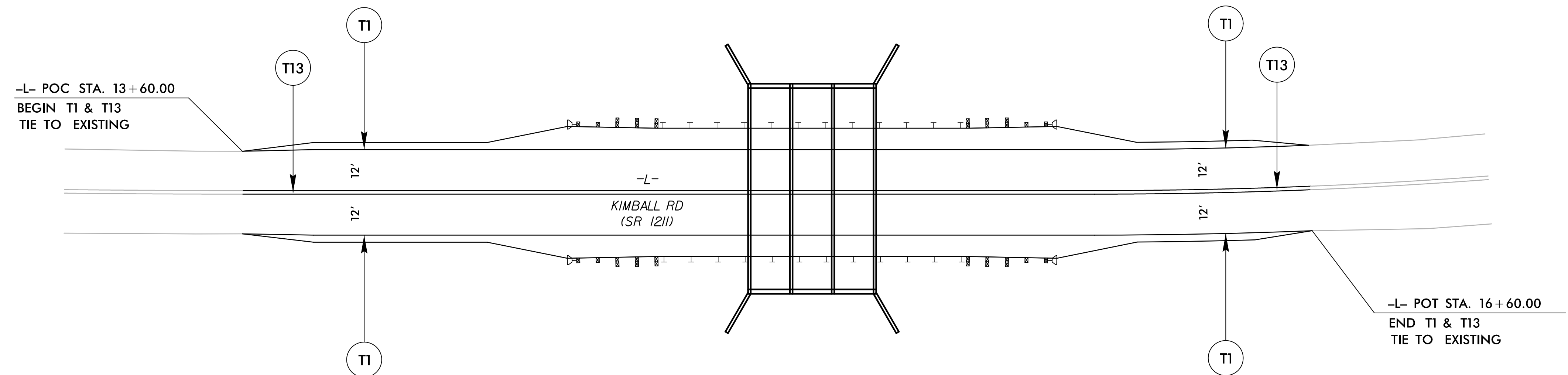
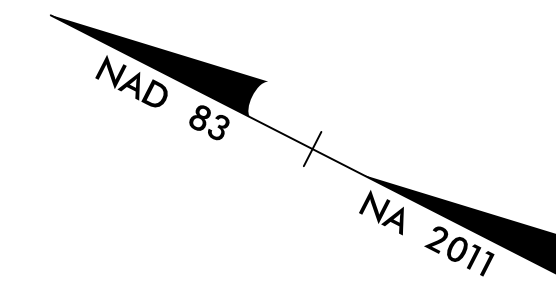

3/31/2022
 R:\Tr\Office\Tr\office\Contr\o\l\TCP\N.R.82.rdy.pmp01.dgn
 SaucieSL

09/08/99

See Sheet 1A For Index of Sheets
See Sheet 1B For Standard Symboly Sheet

STATE	STATE PROJECT REFERENCE NO.	SHEET NO.	TOTAL SHEETS
N.C.	17BP.9.R.82	EC-1	9
STATE PROJ. NO.	F.A. PROJ. NO.	DESCRIPTION	

TIP PROJECT: 17BP.9.R.82

STATE OF NORTH CAROLINA
DIVISION OF HIGHWAYS
HIGHWAY EROSION CONTROL
ROWAN COUNTY

LOCATION: BRIDGE #248 OVER GRANTS CREEK ON SR 1211 (KIMBALL RD)
TYPE OF WORK: GRADING, PAVING, DRAINAGE, & STRUCTURE

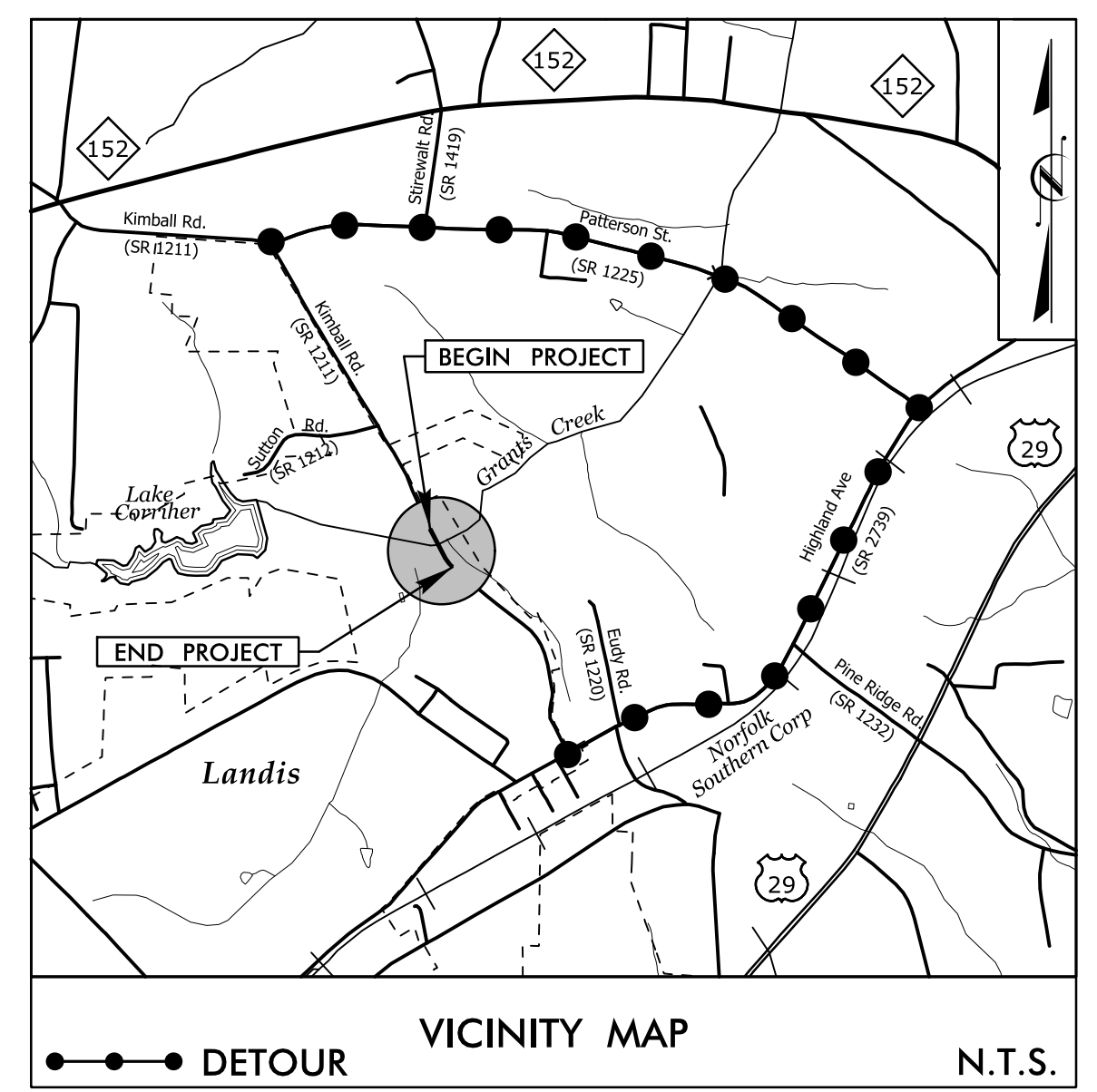

DETOUR VICINITY MAP N.T.S.

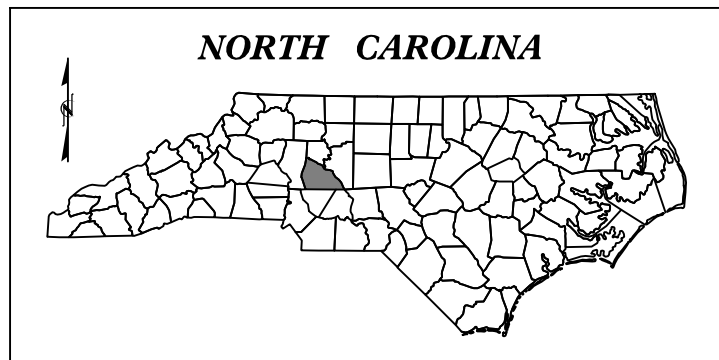
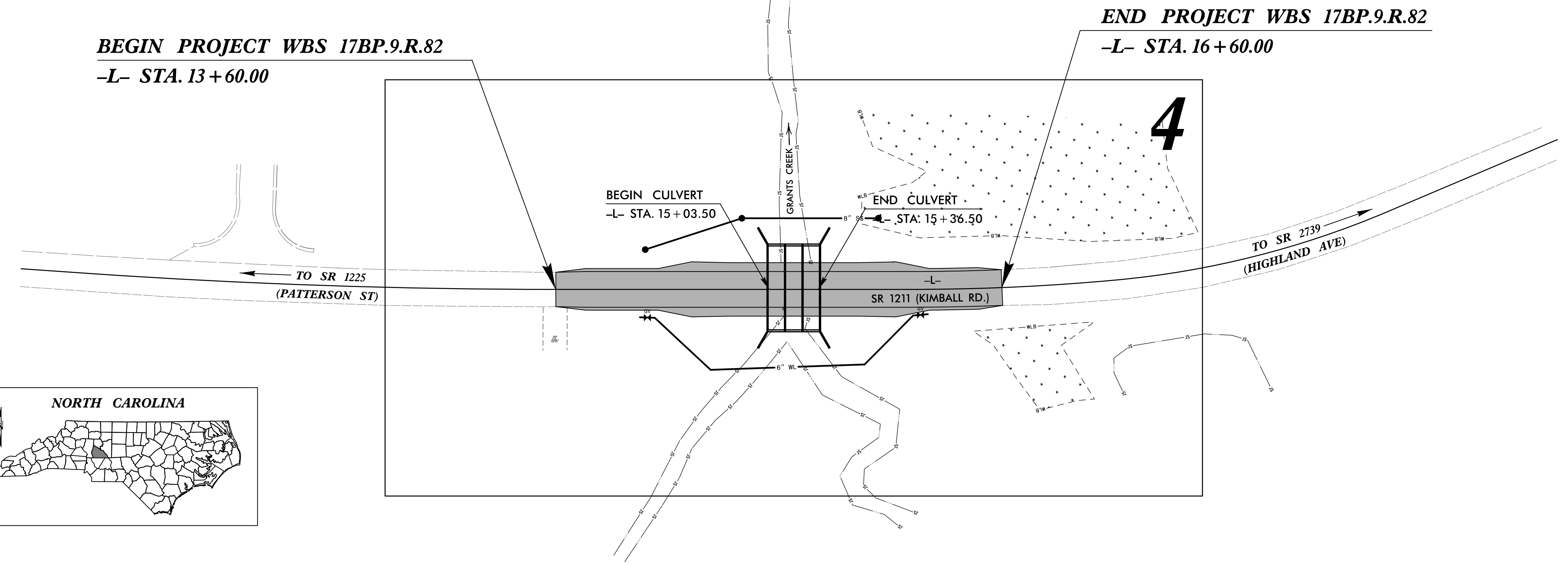
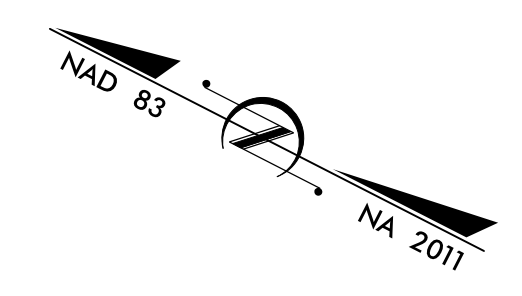

EROSION AND SEDIMENT CONTROL MEASURES

Std. #	Description	Symbol
1630.03	Temporary Silt Ditch	TD
1630.05	Temporary Diversion	TD
1605.01	Temporary Silt Fence	
1606.01	Special Sediment Control Fence	▲▲▲
1622.01	Temporary Berms and Slope Drains	—
1630.02	Silt Basin Type B	▨
1633.01	Temporary Rock Silt Check Type-A	▨
	Temporary Rock Silt Check Type-A with Matting and Polyacrylamide (PAM)	▨
1633.02	Temporary Rock Silt Check Type-B	▨
	Wattle / Coir Fiber Wattle	—
	Wattle / Coir Fiber Wattle with Polyacrylamide (PAM)	—
1634.01	Temporary Rock Sediment Dam Type-A	▨
1634.02	Temporary Rock Sediment Dam Type-B	▨
1635.01	Rock Pipe Inlet Sediment Trap Type-A	▨
1635.02	Rock Pipe Inlet Sediment Trap Type-B	▨
1630.04	Stilling Basin	▨
1630.06	Special Stilling Basin	▨
	Rock Inlet Sediment Trap:	
1632.01	Type A	A
1632.02	Type B	B
1632.03	Type C	C
	Skimmer Basin	▨
	Tiered Skimmer Basin	▨
	Infiltration Basin	▨

THIS PROJECT CONTAINS EROSION CONTROL PLANS FOR CLEARING AND GRUBBING PHASE OF CONSTRUCTION.

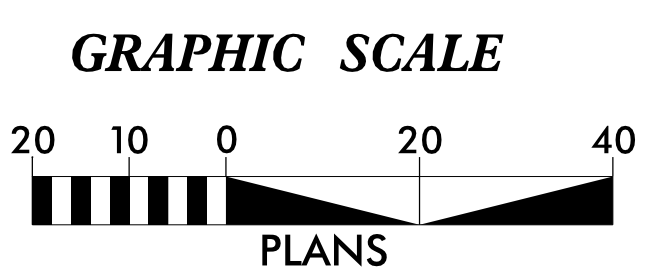

THESE EROSION AND SEDIMENT CONTROL PLANS COMPLY WITH THE APPLICABLE REGULATIONS SET FORTH BY THE NCG-010000 GENERAL CONSTRUCTION PERMIT EFFECTIVE APRIL 1, 2019 AND ISSUED BY THE NORTH CAROLINA DEPARTMENT OF ENVIRONMENTAL QUALITY DIVISION OF WATER RESOURCES.



STV Engineers, Inc.
900 West Trade St., Suite 715
Charlotte, NC 28202
NC License Number F-0991

Prepared In the Office of:
STV ENGINEERS, INC.
900 WEST TRADE STREET, SUITE 715
CHARLOTTE, NC 28202

Designed by:
PETER WALDRON, PE 4352
NAME LEVEL III CERTIFICATION NO.

Roadway Standard Drawings

The following roadway english standards as appear in "Roadway Standard Drawings"- Roadway Design Unit - N. C. Department of Transportation - Raleigh, N. C., dated January 2018 and the latest revision thereto are applicable to this project and by reference hereby are considered a part of these plans.

1604.01	Railroad Erosion Control Detail	1632.01	Rock Inlet Sediment Trap Type A
1605.01	Temporary Silt Fence	1632.02	Rock Inlet Sediment Trap Type B
1606.01	Special Sediment Control Fence	1632.03	Rock Inlet Sediment Trap Type C
1607.01	Gravel Construction Entrance	1633.01	Temporary Rock Silt Check Type A
1622.01	Temporary Berms and Slope Drains	1633.02	Temporary Rock Silt Check Type B
1630.01	Riser Basin	1634.01	Temporary Rock Sediment Dam Type A
1630.02	Silt Basin Type B	1634.02	Temporary Rock Sediment Dam Type B
1630.03	Temporary Silt Ditch	1635.01	Rock Pipe Inlet Sediment Trap Type A
1630.04	Stilling Basin	1635.02	Rock Pipe Inlet Sediment Trap Type B
1630.05	Temporary Diversion	1640.01	Coir Fiber Baffle
1630.06	Special Stilling Basin	1645.01	Temporary Stream Crossing
1631.01	Matting Installation		

3/23/2022 R:\Environmental\Design\Sheets\17BP.9.R.82-EC-TSH.dgn WaldroPB

8/17/99

PROJECT REFERENCE NO. 17BP.9.R.82	SHEET NO. EC-2
RW SHEET NO.	
ROADWAY DESIGN ENGINEER	HYDRAULICS ENGINEER

TEMPORARY ROCK SILT CHECK TYPE 'A' WITH EXCELSIOR MATTING AND POLYACRYLAMIDE (PAM)

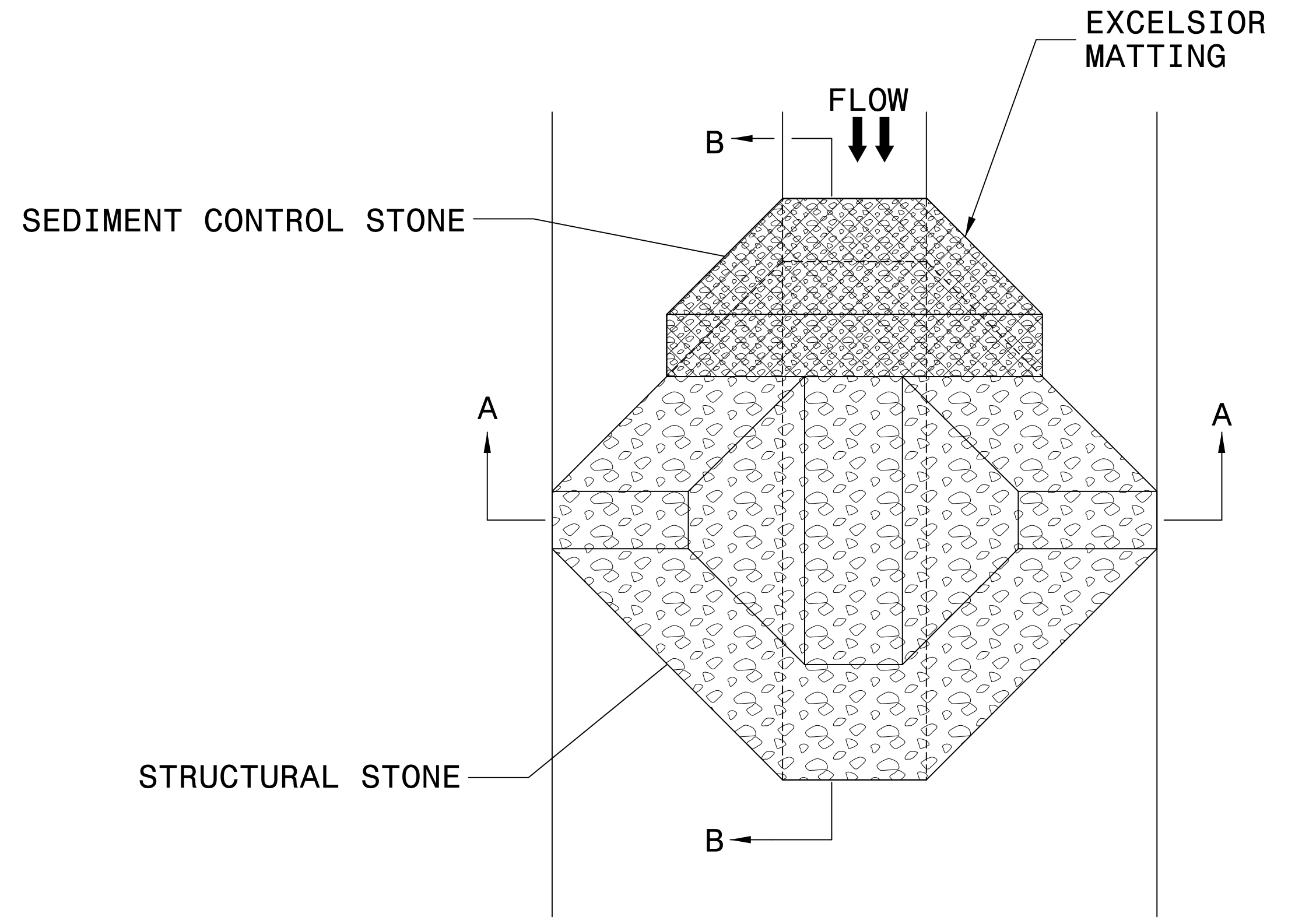

PLAN

NOTES:

INSTALL TEMPORARY ROCK SILT CHECK TYPE A IN ACCORDANCE WITH ROADWAY STANDARD DRAWING NO. 1633.01.

USE EXCELSIOR FOR MATTING MATERIAL AND ANCHOR MATTING SECTION AT TOP AND BOTTOM WITH CLASS B STONE.

PRIOR TO POLYACRYLAMIDE (PAM) APPLICATION, OBTAIN A SOIL SAMPLE FROM PROJECT LOCATION, AND FROM OFFSITE MATERIAL, AND ANALYZE FOR APPROPRIATE PAM FLOCCULANT TO BE APPLIED TO EACH ROCK SILT CHECK.

INITIALLY APPLY 4 OUNCES OF POLYACRYLAMIDE (PAM) TO TOP OF MATTING SECTION AND AFTER EVERY RAINFALL EVENT THAT EQUALS OR EXCEEDS 0.50 INCHES.

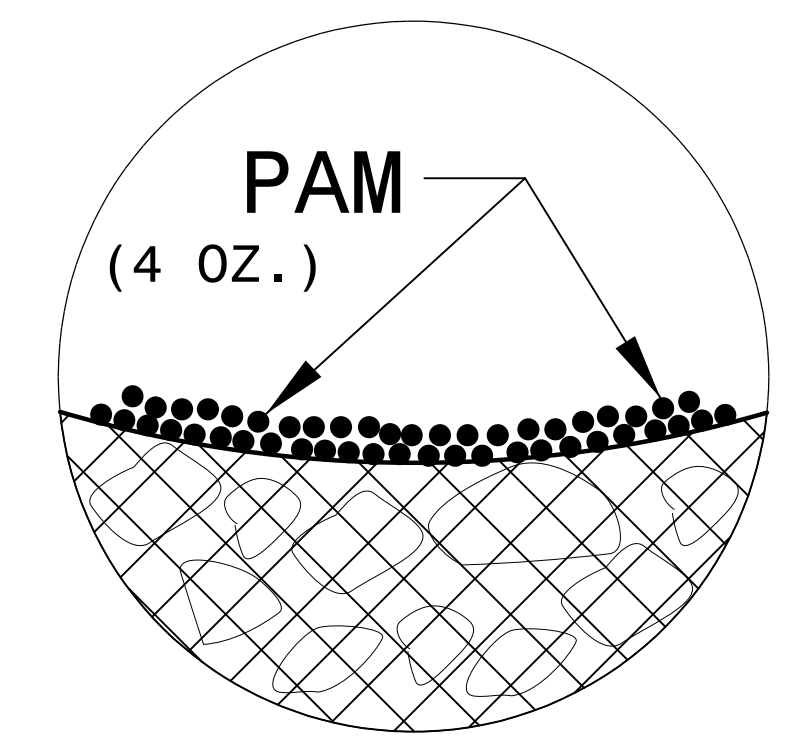

INSET A

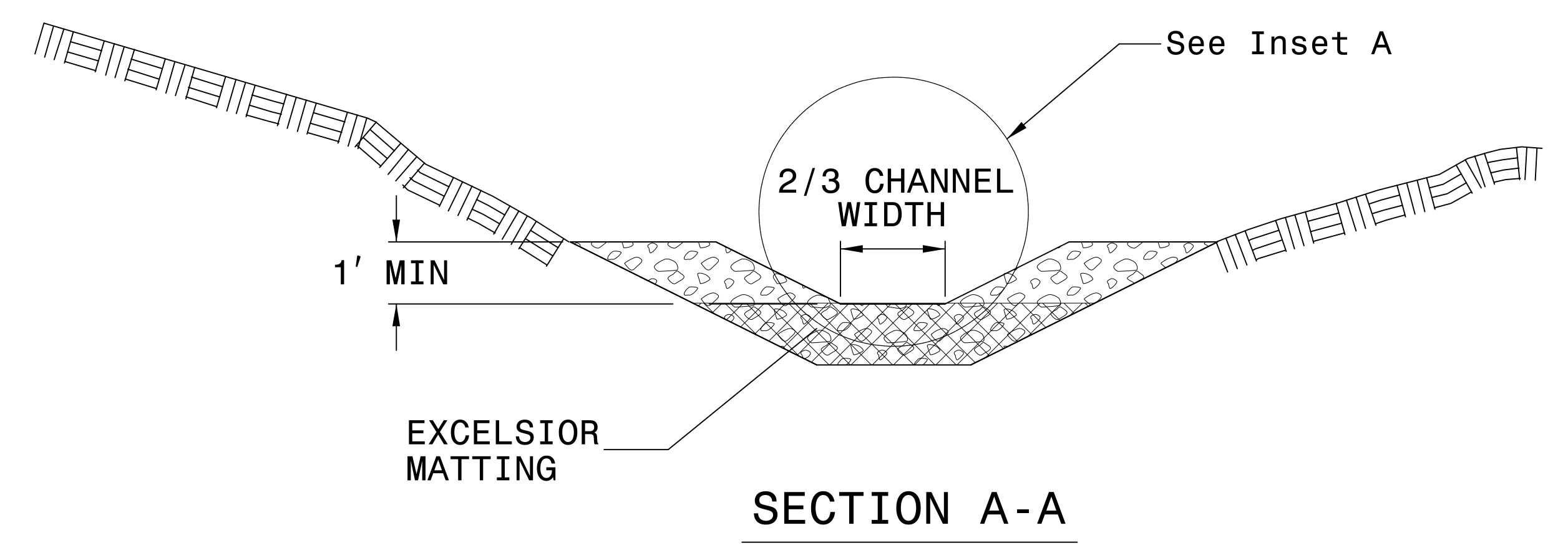

SECTION A-A

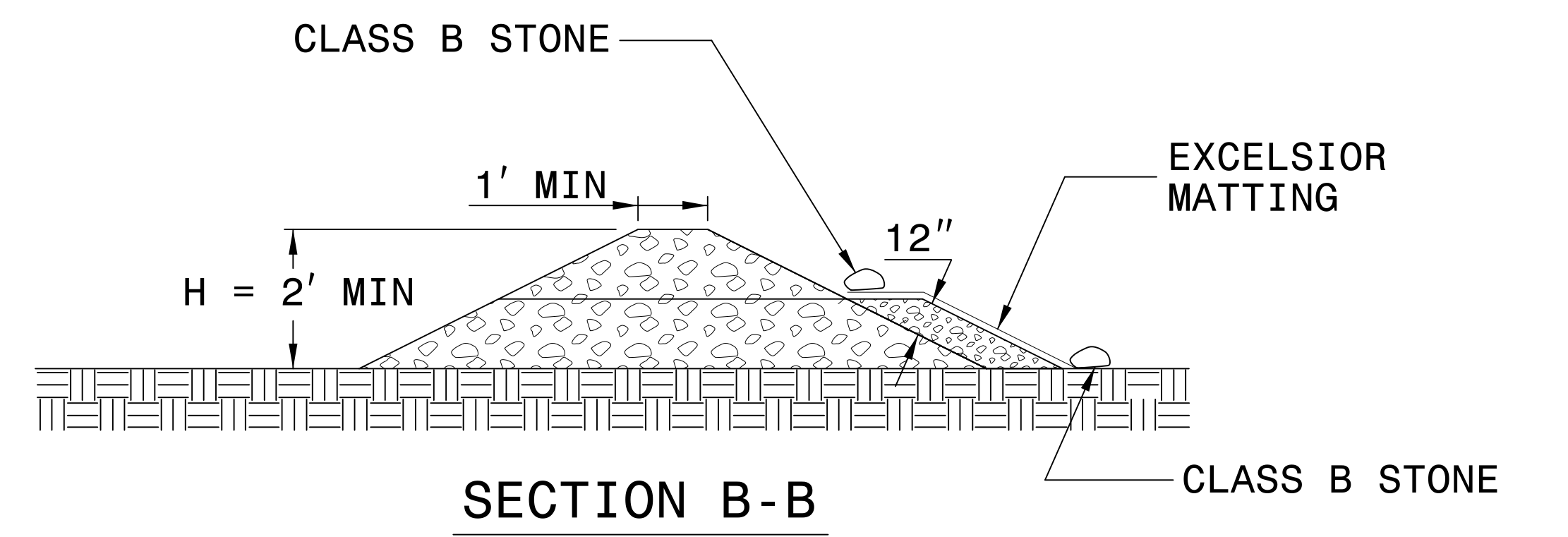

SECTION B-B

NOT TO SCALE

3/23/2022
R:\Environmental\Detail\82_EC_TRSC-A_Detail.psh2.dgn
W:\pfb

8/17/99

PROJECT REFERENCE NO.		SHEET NO.	
17BP.9.R.82		EC-2A	
RW SHEET NO.			
ROADWAY DESIGN ENGINEER		HYDRAULICS ENGINEER	

SILT FENCE COIR FIBER WATTLE BREAK DETAIL

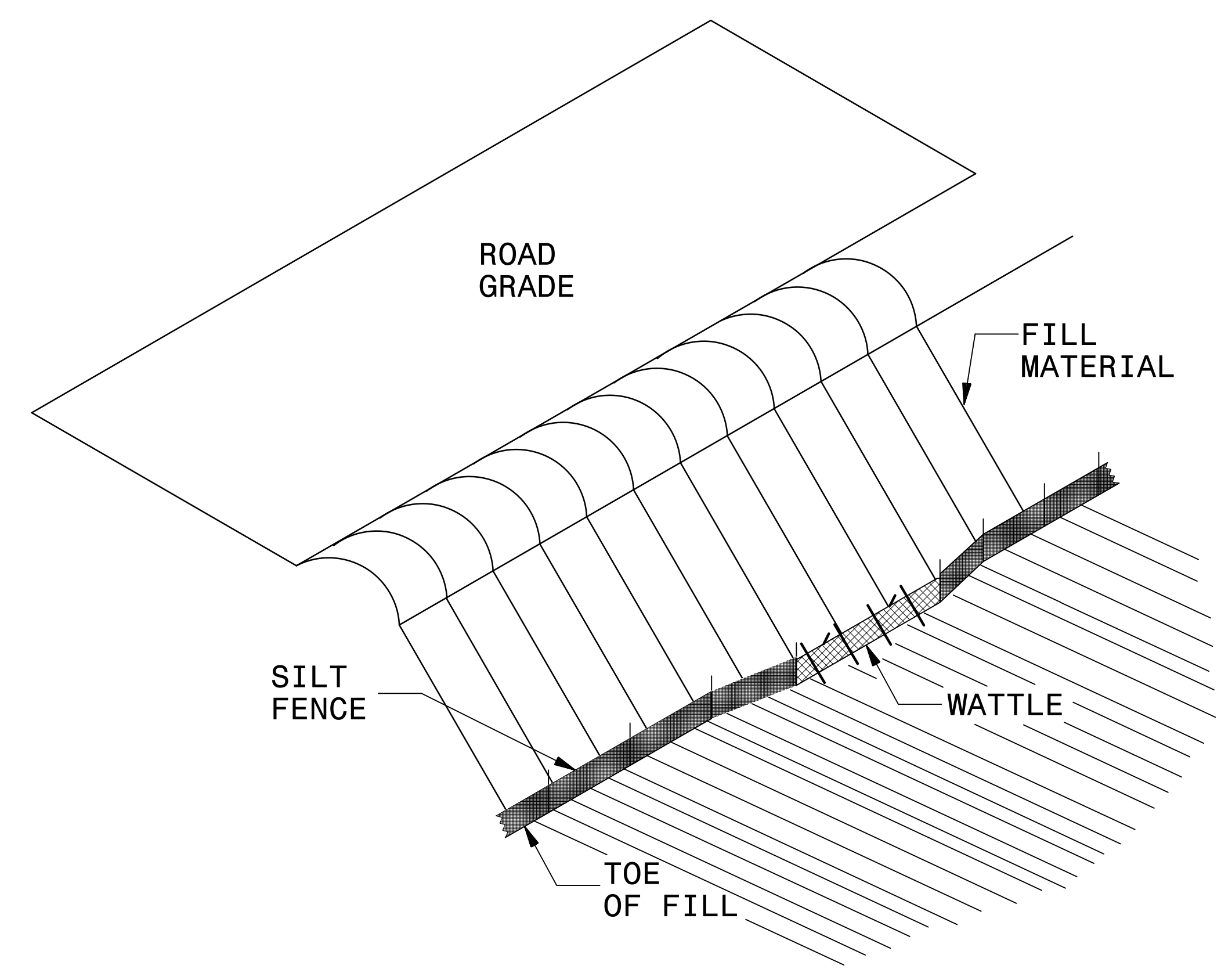

NOTES:

- USE MINIMUM 12 IN. DIAMETER COIR FIBER (COCONUT FIBER) WATTLE AND LENGTH OF 10 FT.
- EXCAVATE A 1 TO 2 INCH TRENCH FOR WATTLE TO BE PLACED.
- DO NOT PLACE WATTLE ON TOE OF SLOPE.
- USE 2 FT. WOODEN STAKES WITH A 2 IN. BY 2 IN. NOMINAL CROSS SECTION.
- INSTALL A MINIMUM OF 2 UPSLOPE STAKES AND 4 DOWNSLOPE STAKES AT AN ANGLE TO WEDGE WATTLE TO GROUND.
- PROVIDE STAPLES MADE OF 0.125 IN. DIAMETER STEEL WIRE FORMED INTO A U SHAPE NOT LESS THAN 12" IN LENGTH.
- INSTALL STAPLES APPROXIMATELY EVERY 1 LINEAR FOOT ON BOTH SIDES OF WATTLE AND AT EACH END TO SECURE IT TO THE SOIL.
- WATTLE INSTALLATION CAN BE ON OUTSIDE OF THE SILT FENCE AS DIRECTED.
- INSTALL TEMPORARY SILT FENCE IN ACCORDANCE WITH SECTION 1605 OF THE STANDARD SPECIFICATIONS.

INSET A

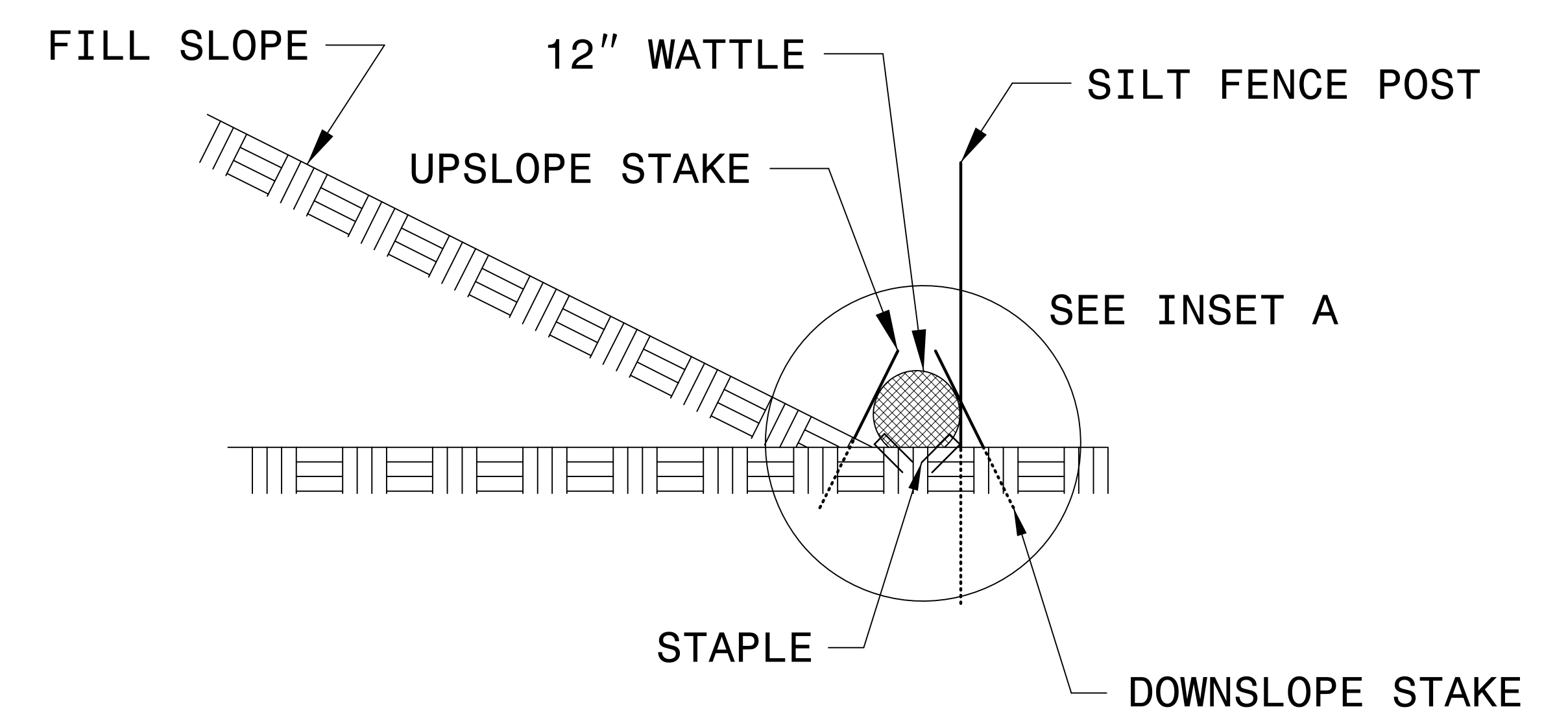
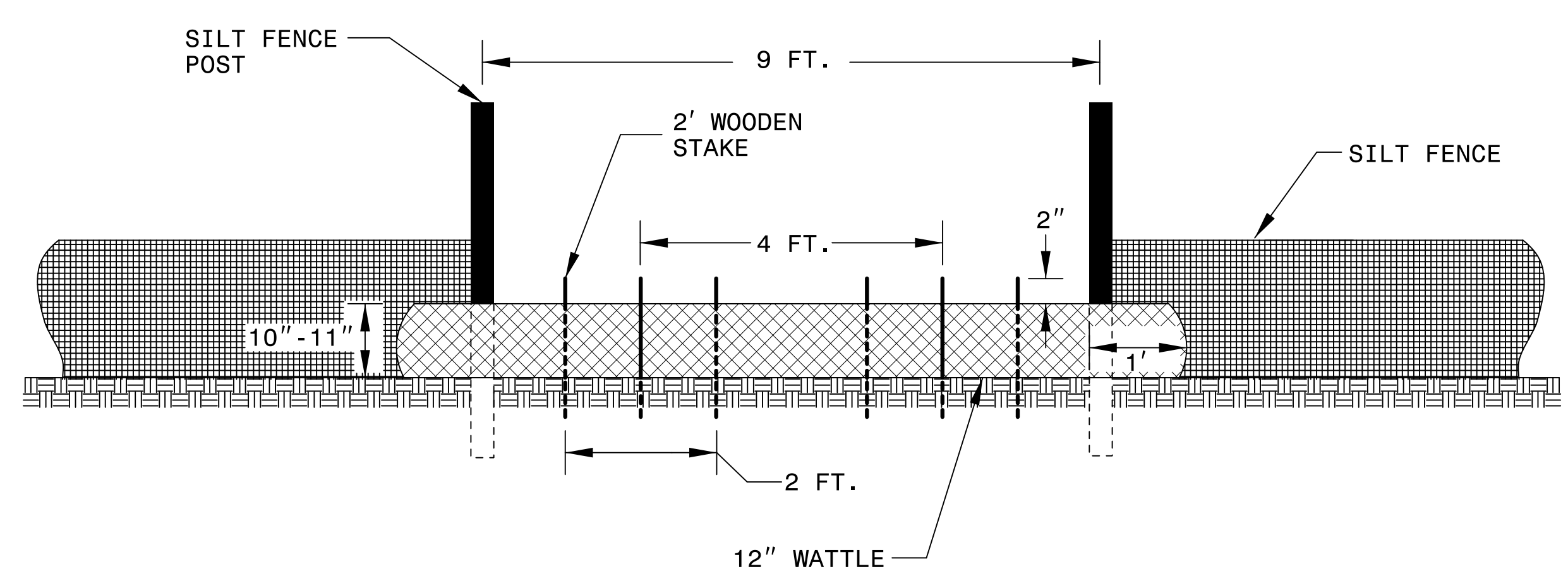
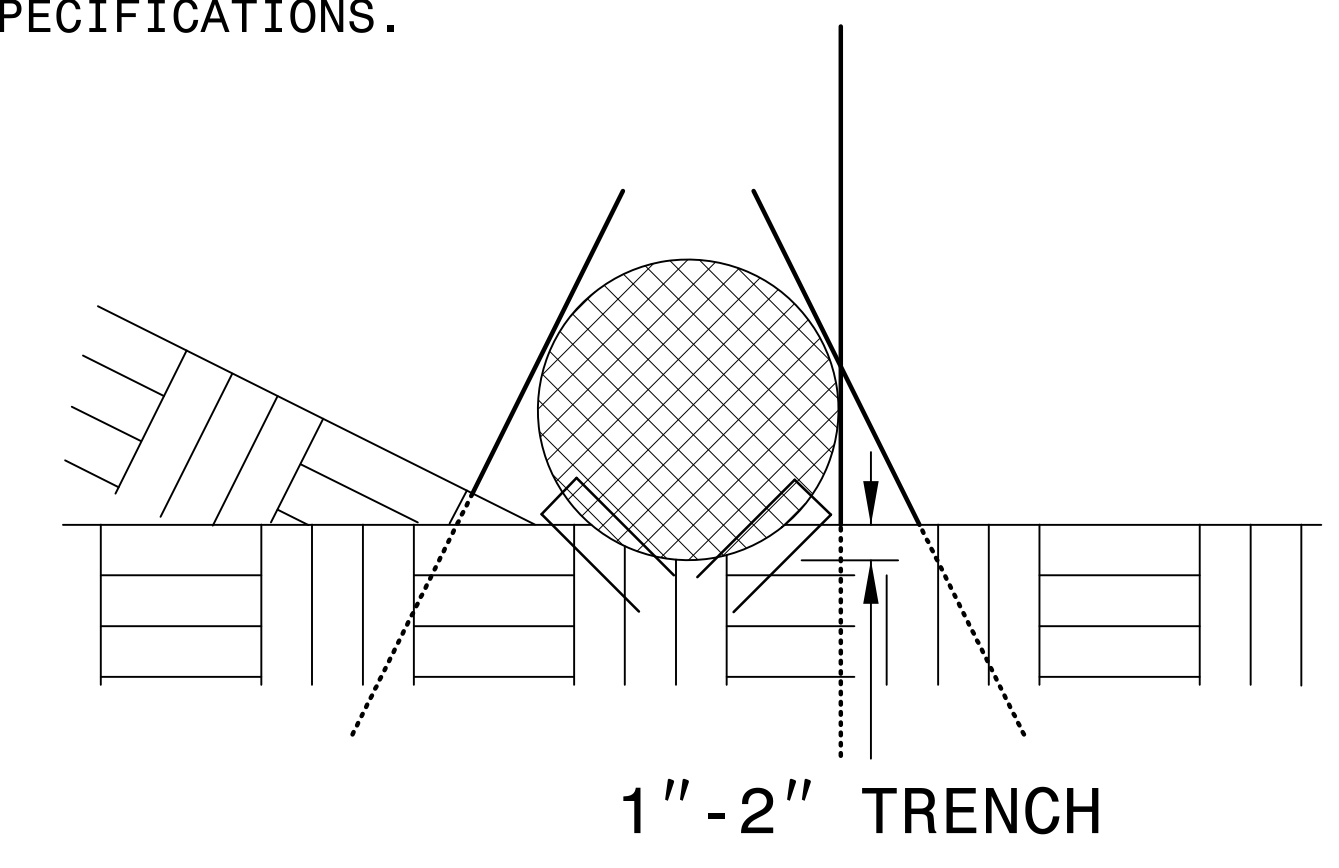

3/23/2022
R:\Environmental\Details\82_EC_CFW_Break_Detail.psh24.dgn
W:\gropB

DIVISION OF HIGHWAYS
STATE OF NORTH CAROLINA

PROJECT REFERENCE NO. <i>17BP.9.R.82</i>	SHEET NO. <i>EC-3A</i>
ROADWAY DESIGN ENGINEER	HYDRAULICS ENGINEER

SOIL STABILIZATION TIMEFRAMES

SITE DESCRIPTION	STABILIZATION TIME	TIMEFRAME EXCEPTIONS
PERIMETER DIKES, SWALES, DITCHES AND SLOPES	7 DAYS	NONE
HIGH QUALITY WATER (HQW) ZONES	7 DAYS	NONE
SLOPES STEEPER THAN 3:1	7 DAYS	IF SLOPES ARE 10' OR LESS IN LENGTH AND ARE NOT STEEPER THAN 2:1, 14 DAYS ARE ALLOWED.
SLOPES 3:1 OR FLATTER	14 DAYS	7 DAYS FOR SLOPES GREATER THAN 50' IN LENGTH.
ALL OTHER AREAS WITH SLOPES FLATTER THAN 4:1	14 DAYS	NONE, EXCEPT FOR PERIMETERS AND HQW ZONES.

PROJECT REFERENCE NO. <i>17BP.9.R.82</i>	SHEET NO. EC-4/CONST 4
RW SHEET NO.	
ROADWAY DESIGN ENGINEER	HYDRAULICS ENGINEER
DOCUMENT NOT CONSIDERED FINAL UNLESS ALL SIGNATURES COMPLETED	

CLEARING AND GRUBBING
 EROSION CONTROL FOR
 CONSTRUCTION SHEET 4

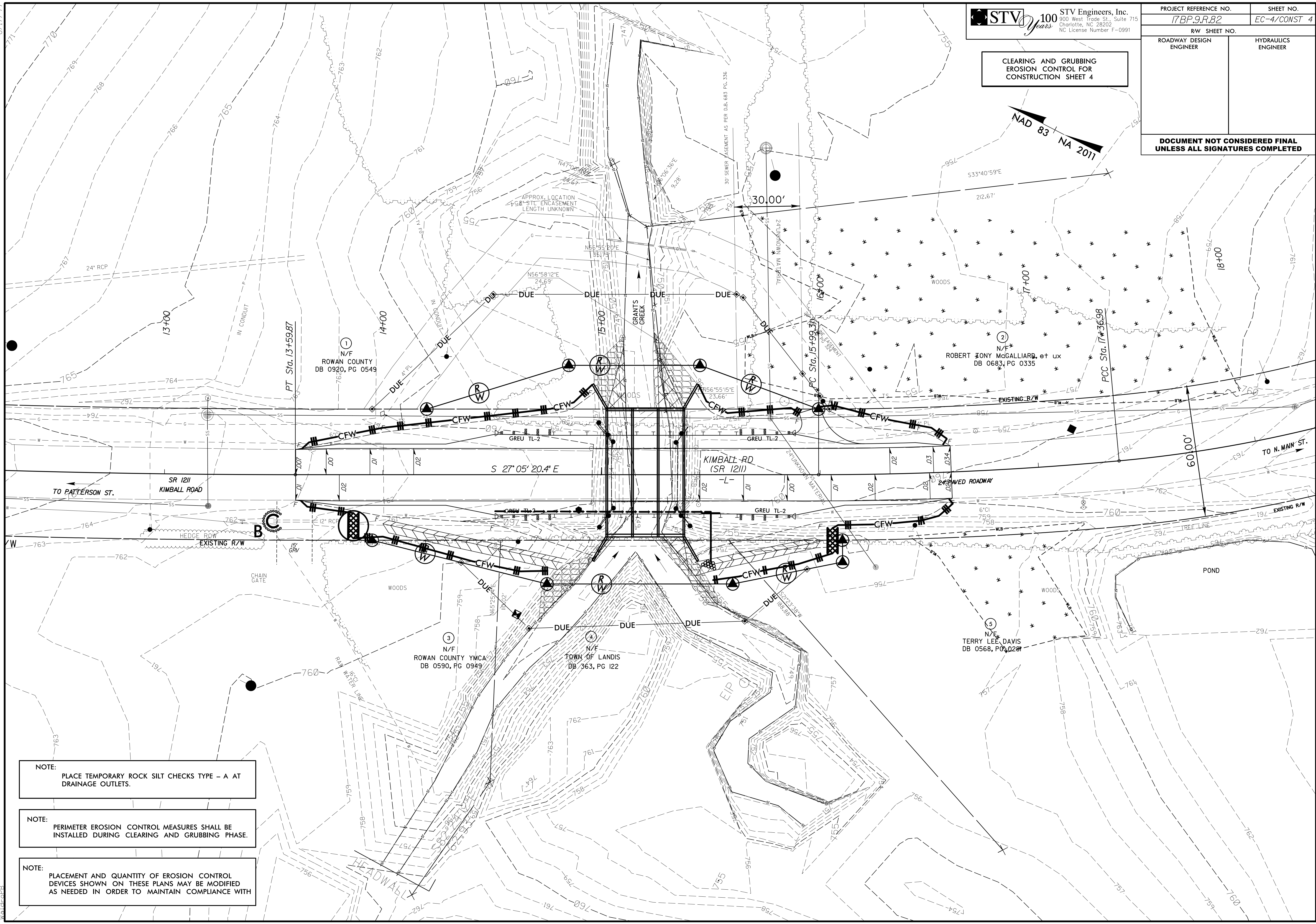
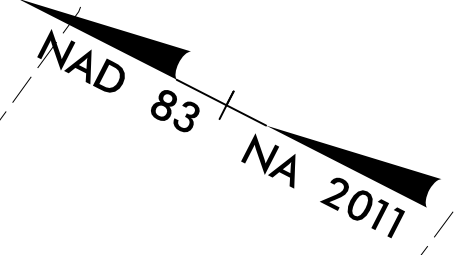

NOTE:
 PLACE TEMPORARY ROCK SILT CHECKS TYPE - A AT DRAINAGE OUTLETS.

NOTE:
 PERIMETER EROSION CONTROL MEASURES SHALL BE INSTALLED DURING CLEARING AND GRUBBING PHASE.

NOTE:
 PLACEMENT AND QUANTITY OF EROSION CONTROL DEVICES SHOWN ON THESE PLANS MAY BE MODIFIED AS NEEDED IN ORDER TO MAINTAIN COMPLIANCE WITH

3/23/2022
 R:\Projects\2022\Environmental\Design\Sheets\17BP.9.R.82_EC.CG.psh.04.dgn
 Valid: 3/23/2022

CULVERT CONSTRUCTION SEQUENCE STA. 15+20 -L-

PHASE I

1. INSTALL SPECIAL STILLING BASINS AS DIRECTED.
2. INSTALL IMPERVIOUS DIKE A, DIVERTING FLOW THROUGH EXISTING CHANNEL AND REMOVE EXISTING BRIDGE.
3. DEWATER CULVERT CONSTRUCTION AREA AND EXCAVATE ANY ACCUMULATED SILT.
4. CONSTRUCT THE TWO NORTHERN LOW FLOW BARRELS OF THE 11'X8' RC BOX CULVERT.

PHASE II

5. EXCAVATE ANY ACCUMULATED SILT AND DEWATER BEFORE REMOVAL OF IMPERVIOUS DIKES A.
6. REMOVE IMPERVIOUS DIKE A.
7. INSTALL IMPERVIOUS DIKES B, DIVERTING FLOW THROUGH CONSTRUCTED LOW FLOW BARRELS.
8. CONSTRUCT FINAL 11'X8' BARREL OF THE RC BOX CULVERT.

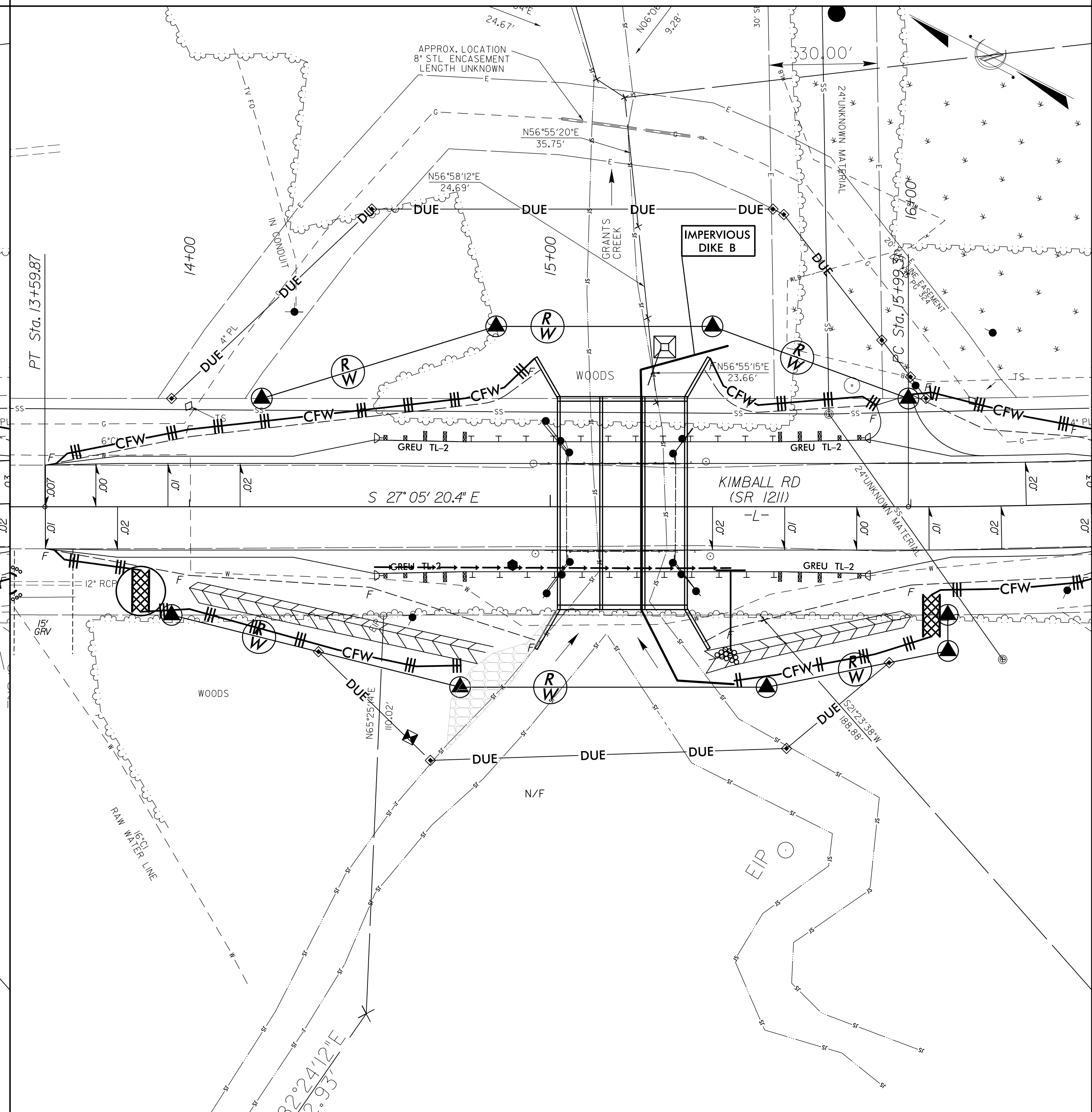
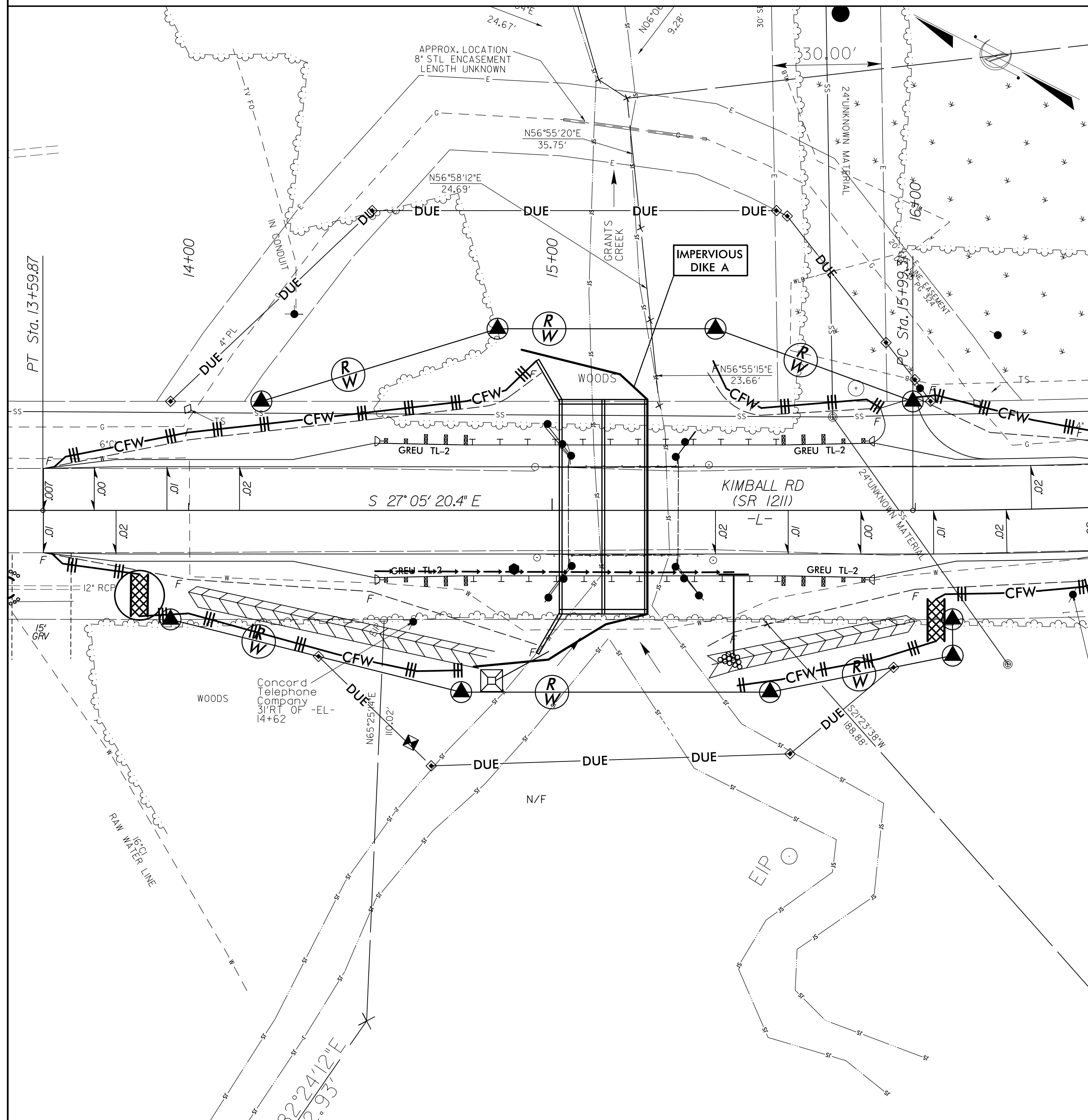

CULVERT CONSTRUCTION SEQUENCE STA. 15+20 -L-

PHASE III

9. EXCAVATE ANY ACCUMULATED SILT AND DEWATER BEFORE REMOVAL OF IMPERVIOUS DIKE B.
10. REMOVE IMPERVIOUS DIKE B AND ALLOW FLOW THROUGH THE PROPOSED 3-11'X8' RC BOX CULVERT.
11. REMOVE SPECIAL STILLING BASINS, STABILIZE DISTURBED AREA, INSTALL RIPRAP BANK STABILIZATION, AND COMPLETE ROADWAY.

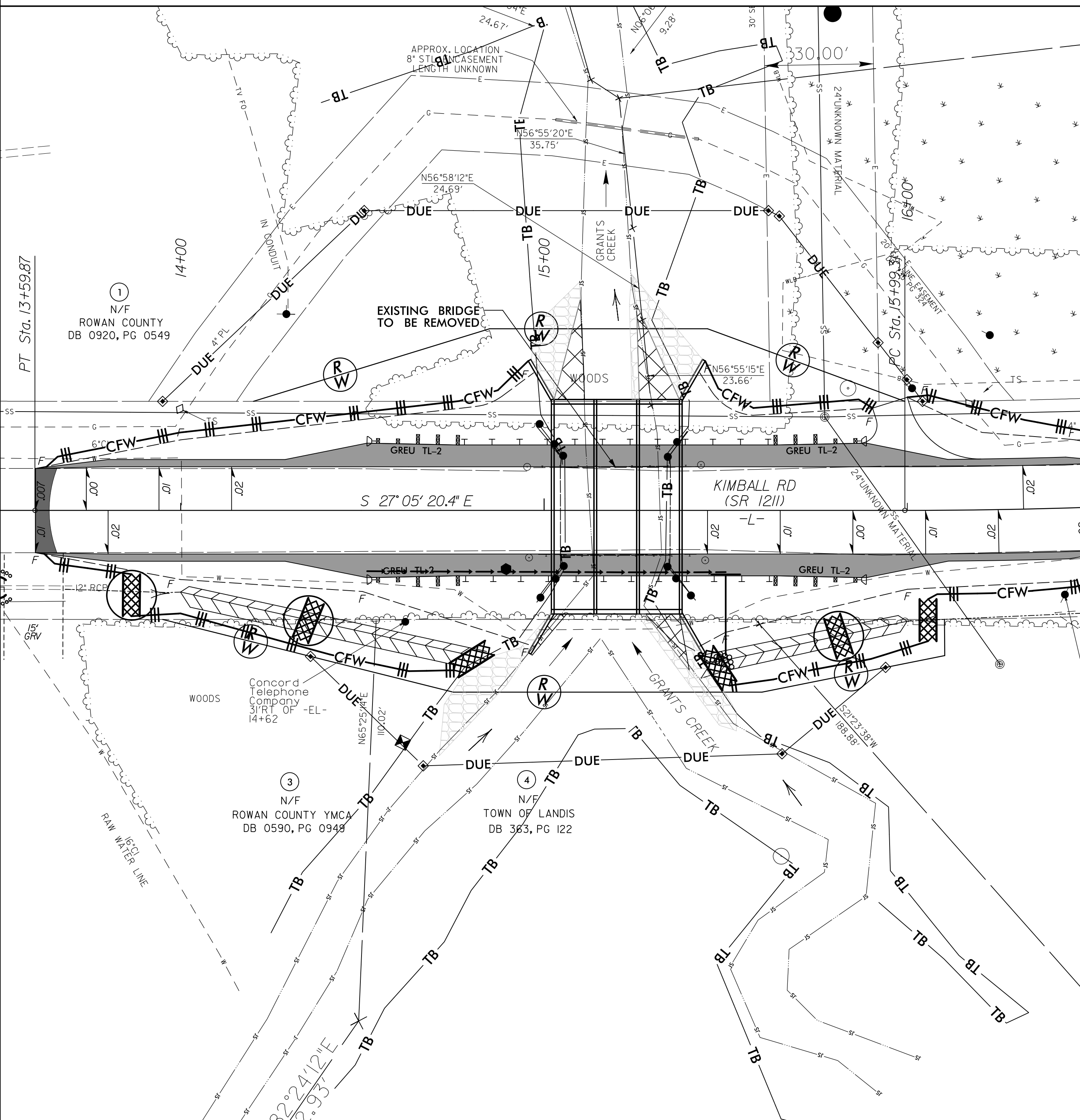

8/17/99

STV 100 Years
 STV Engineers, Inc.
 300 West Trade St., Suite 715
 Charlotte, NC 28202
 NC License Number F-0991

PROJECT REFERENCE NO. 17BP.9.R.82	SHEET NO. EC-5/CONST 4
ROADWAY DESIGN ENGINEER	HYDRAULICS ENGINEER
DOCUMENT NOT CONSIDERED FINAL UNLESS ALL SIGNATURES COMPLETED	

FINAL PHASE
 EROSION CONTROL FOR
 CONSTRUCTION SHEET 4

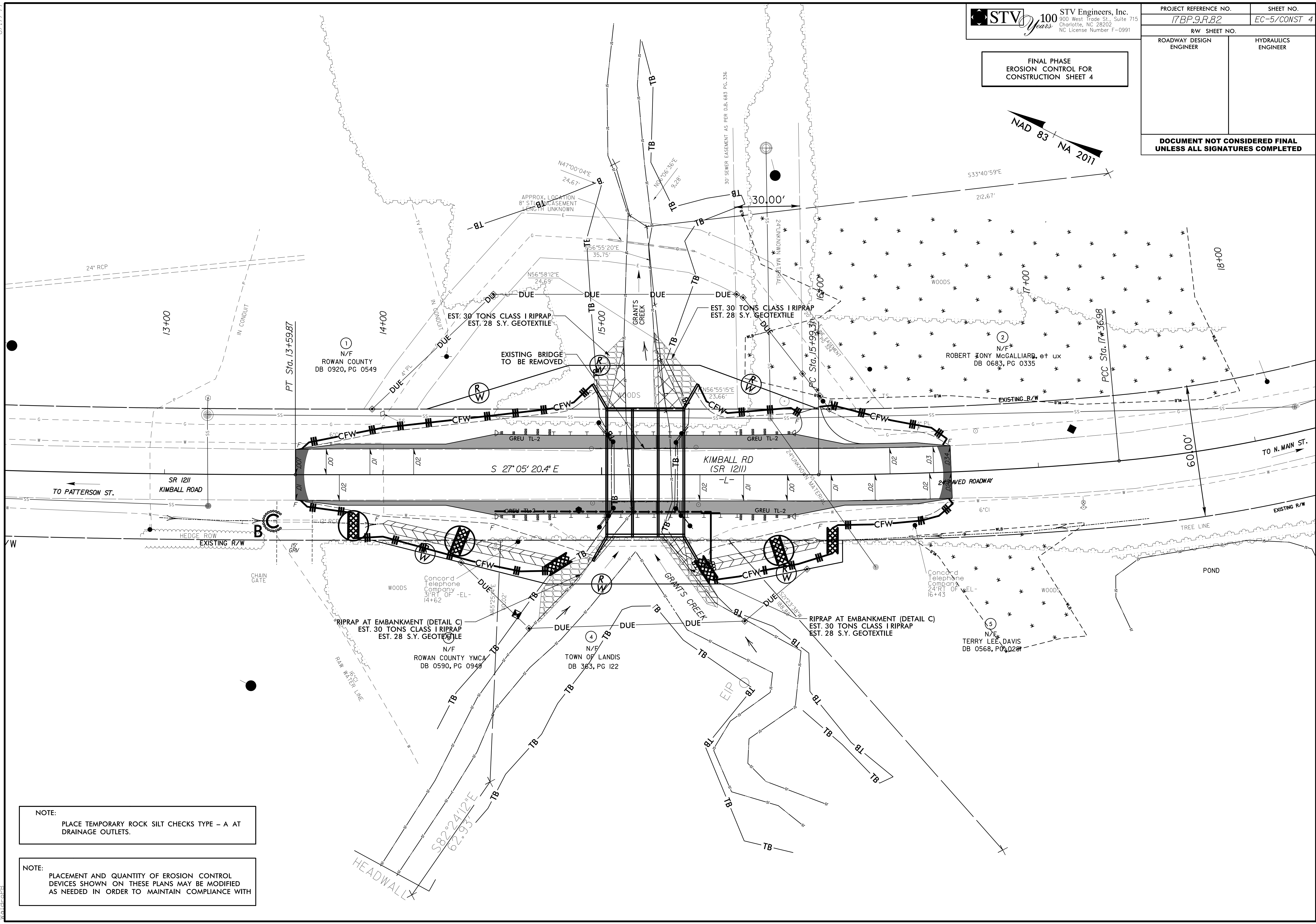
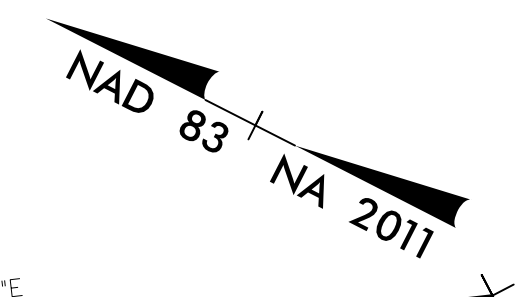

NOTE:
 PLACE TEMPORARY ROCK SILT CHECKS TYPE - A AT DRAINAGE OUTLETS.

NOTE:
 PLACEMENT AND QUANTITY OF EROSION CONTROL DEVICES SHOWN ON THESE PLANS MAY BE MODIFIED AS NEEDED IN ORDER TO MAINTAIN COMPLIANCE WITH

3/23/2022
 R:\Projects\2022\Environmental\Design\Sheets\17BP.9.R.82_EC_FP_psh_05.dgn
 W:\Projects\2022\Environmental\Design\Sheets\17BP.9.R.82_EC_FP_psh_05.dgn

09.08.99

PROJECT WBS: 17BP.9.R.82

PROJECT WBS:	SHEET NO.
17BP.9.R.82	UO-1

NOTE:
 ALL UTILITY WORK SHOWN ON THIS SHEET IS DONE BY OTHERS.
 NO PAYMENT WILL BE MADE TO THE CONTRACTOR FOR UTILITY WORK SHOWN ON THIS SHEET.

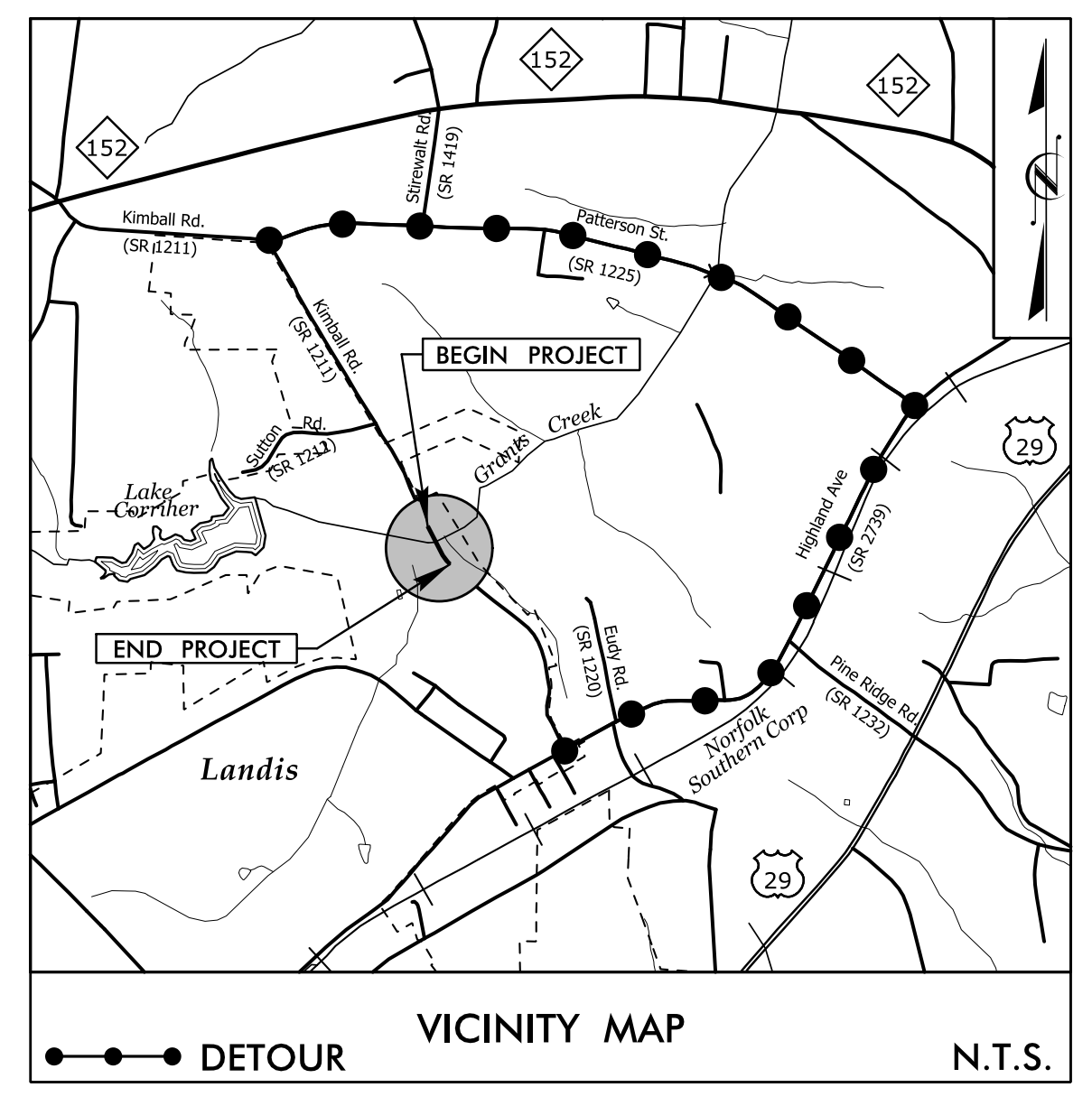
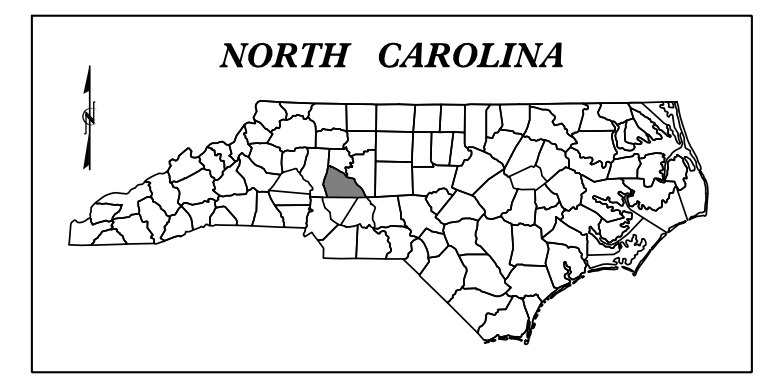

STATE OF NORTH CAROLINA
 DIVISION OF HIGHWAYS

UTILITIES BY OTHERS PLANS ROWAN COUNTY

**LOCATION: BRIDGE #248 OVER GRANTS CREEK
 ON SR 1211 (KIMBALL RD)**

**TYPE OF WORK:
 POWER & TELECOMMUNICATIONS**

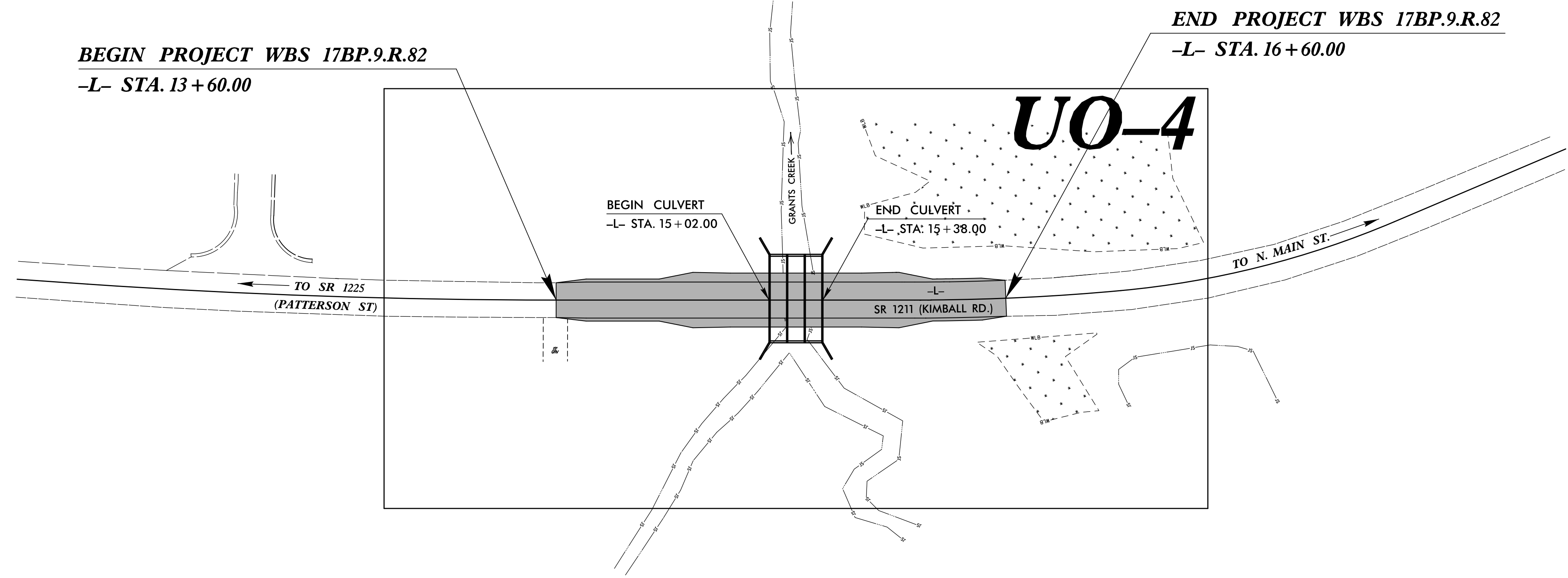
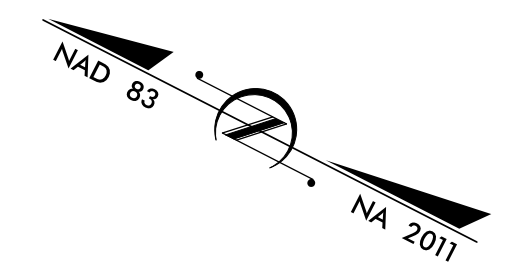

GRAPHIC SCALES

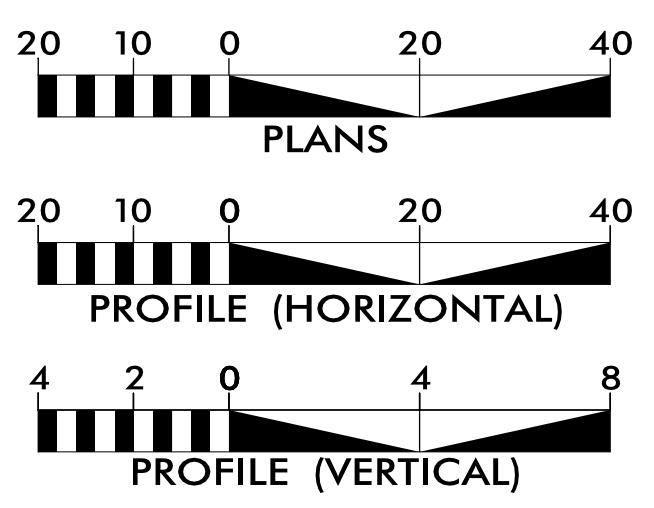

INDEX OF SHEETS

SHEET NO.:	DESCRIPTION:
UO-1	TITLE SHEET
UO-4	UBO PLAN SHEET

UTILITY OWNERS ON PROJECT

- (A) POWER (DISTRIBUTION) - TOWN OF LANDIS
- (B) POWER (DISTRIBUTION) - DUKE ENERGY
- (C) GAS - DOMINION ENERGY
- (D) TELEPHONE - WINDSTREAM
- (E) CATV - CHARTER

PREPARED IN THE OFFICE OF:



Oriana Roumillat, PE UTILITY PROJECT MANAGER
Laura Braunfeld PROJECT UTILITY COORDINATOR
Justin Hill PROJECT UTILITY QA/QC

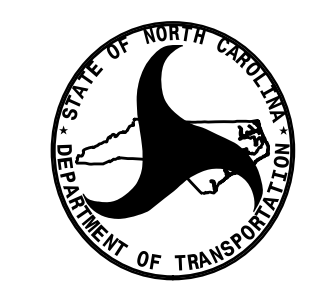

**DIVISION OF HIGHWAYS
 UTILITIES UNIT**
 1555 MAIL SERVICES CENTER
 RALEIGH, NC 27699-1555
 PHONE (919) 707-6690
 FAX (919) 250-4151

Ali Kouchehi, PE UTILITIES REGIONAL ENGINEER
Jon Loughry SENIOR UTILITIES ENGINEER
David Trantham DIV 9 UTILITY ENGINEER
Lynn Basinger DIV 9 UTILITY COORDINATOR

\$\$\$\$\$ SYSTEM \$\$\$\$\$\$
 \$\$\$ DGN \$\$\$
 \$\$\$ USERNAME \$\$\$

5/14/2019

UTILITIES BY OTHERS

NOTE:
 ALL UTILITY WORK SHOWN ON THIS SHEET WILL BE DONE BY OTHERS. NO PAYMENT WILL BE MADE TO THE CONTRACTOR FOR UTILITY WORK SHOWN ON THIS SHEET.

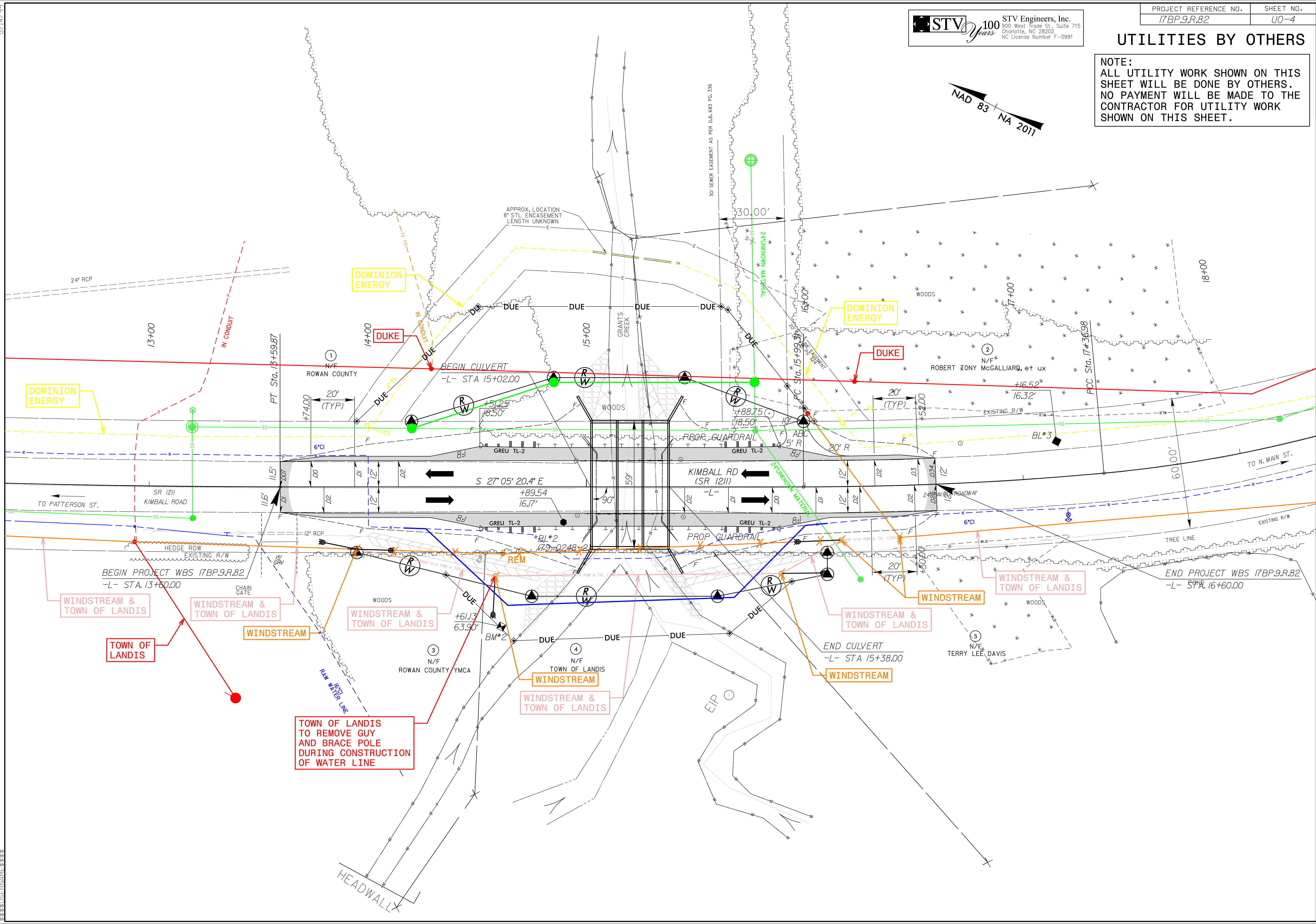
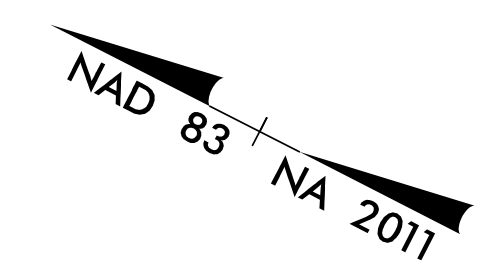

C:\Users\jgibson\OneDrive\Documents\17BP.9.R.82\17BP.9.R.82_U0-4.dwg
 5/14/2019 10:58:54 AM
 jgibson

09.02.82/291

3/25/2022
I:\Projects\4018854\4018854_000\50_Deliverables & Submittals\NR.82_Bridge_248\Utilities\Engineering\UC\Pro\Sheets\NR.82_ut_tsh_UC01_psh.dgn
Akins

PROJECT WBS: 17BP.9.R.82
CONTRACT:

See Sheet UC-1 For Index of Sheets
See Sheet UC-2 For Standard Symbology Sheet

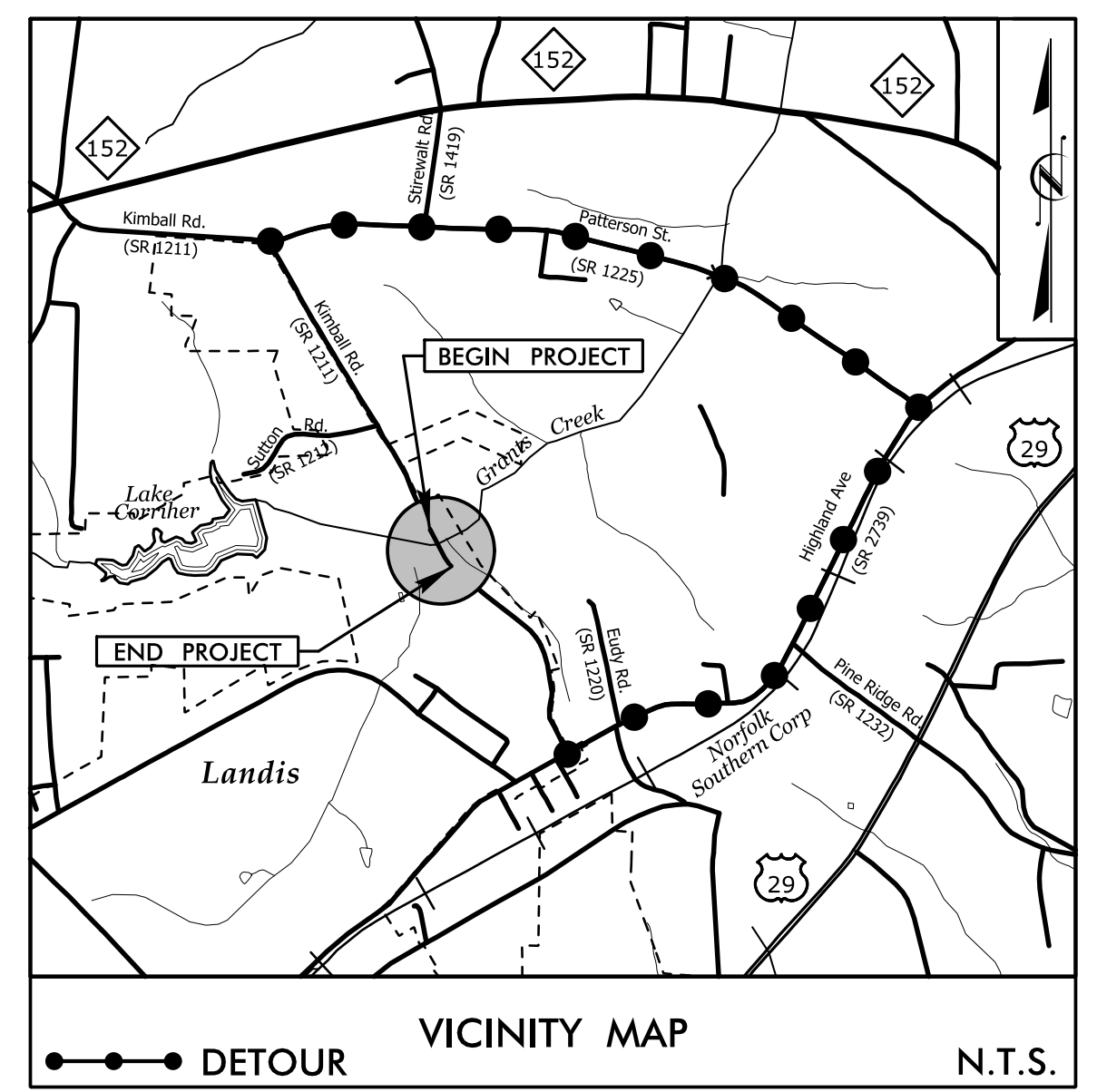

STATE OF NORTH CAROLINA DIVISION OF HIGHWAYS

UTILITY CONSTRUCTION PLANS ROWAN COUNTY

**LOCATION: BRIDGE #248 OVER GRANTS CREEK
ON SR 1211 (KIMBALL RD)**

**TYPE OF WORK: WATER LINE RELOCATION
& SANITARY SEWER RELOCATION**

T.I.P. NO.	SHEET NO.
17BP.9.R.82	UC-1

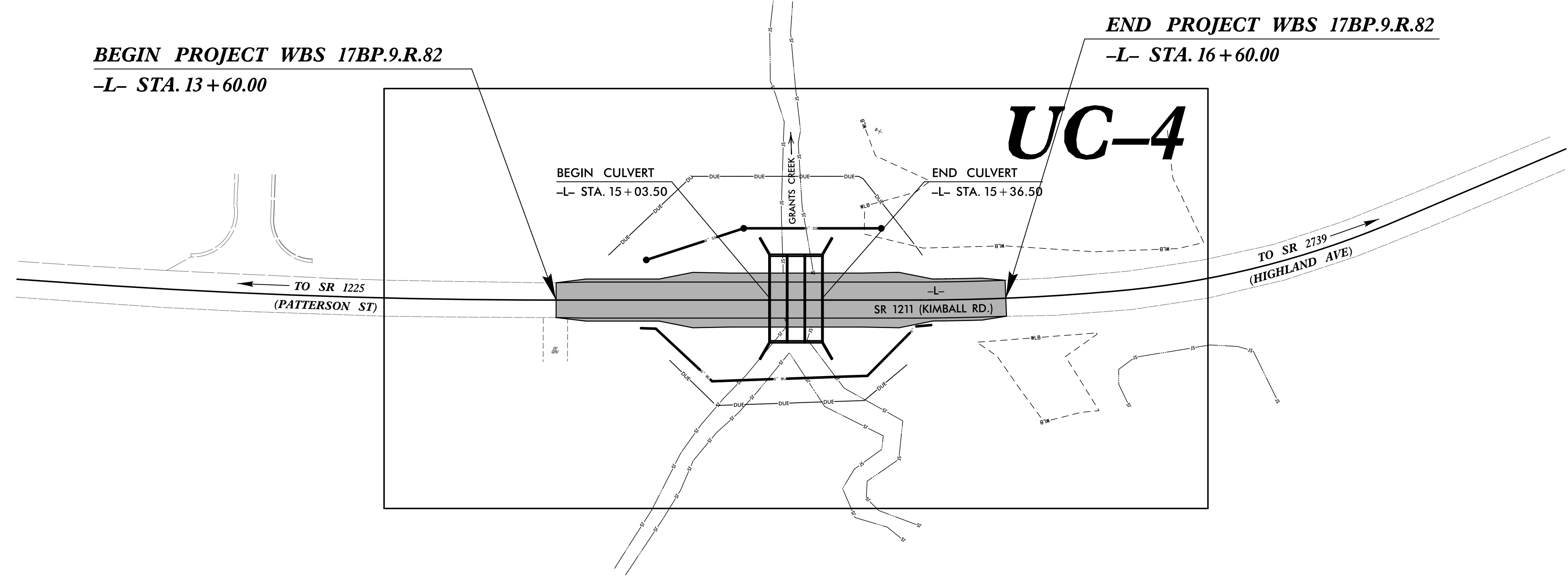
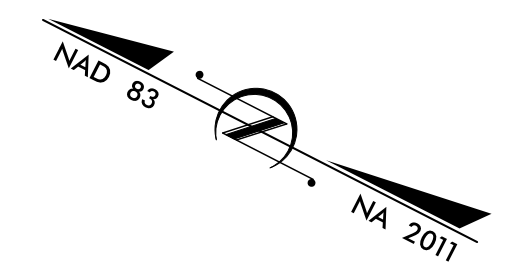
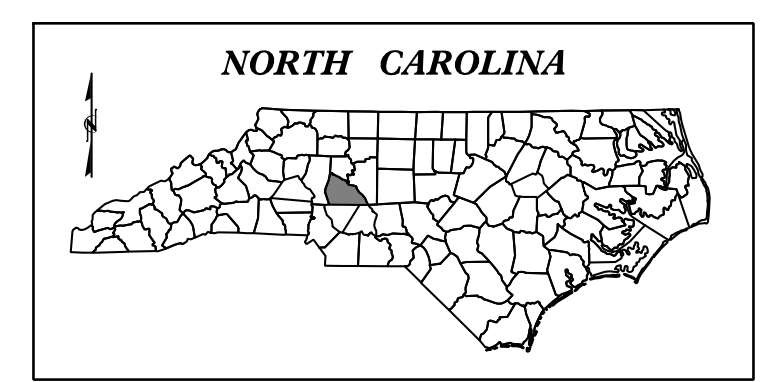

**THIS PROJECT IS WITHIN MUNICIPAL BOUNDARIES OF LANDIS.
CLEARING ON THIS PROJECT SHALL BE PERFORMED
TO THE LIMITS ESTABLISHED BY METHOD II.**

DOCUMENT NOT CONSIDERED FINAL
UNTIL ALL SIGNATURES ARE COMPLETED

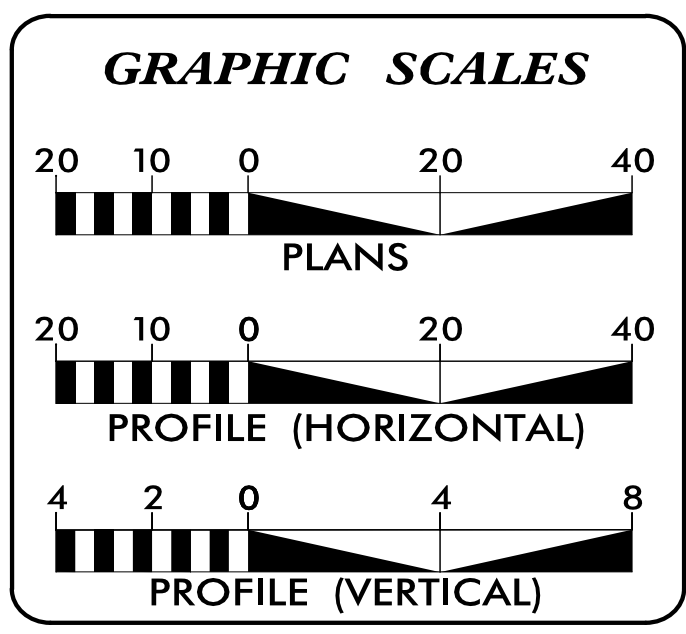

SHEET NO.:	DESCRIPTION:
UC-1	TITLE SHEET
UC-2	UTILITY SYMBOLOGY
UC-3A	NOTES
UC-3B	DETAILS
UC-4	UTILITY CONSTRUCTION SHEET
UC-5	UTILITY PROFILE SHEET

WATER AND SEWER OWNERS ON PROJECT

(A) WATER - TOWN OF LANDIS PUBLIC WORKS DEPARTMENT

(B) SEWER - TOWN OF LANDIS PUBLIC WORKS DEPARTMENT

PREPARED IN THE OFFICE OF

STV 100 Years
STV Engineers, Inc.
900 West Trade St., Suite 715
Charlotte, NC 28202
NC License Number F-0991
(704) 372-1885 FAX: (704) 372-3393

EDWARD VANCE, PE CONSULTANT CONTACT #1
ANDREW VANE, PE CONSULTANT CONTACT #2
NATHAN ADKINS, EI CONSULTANT CONTACT #3

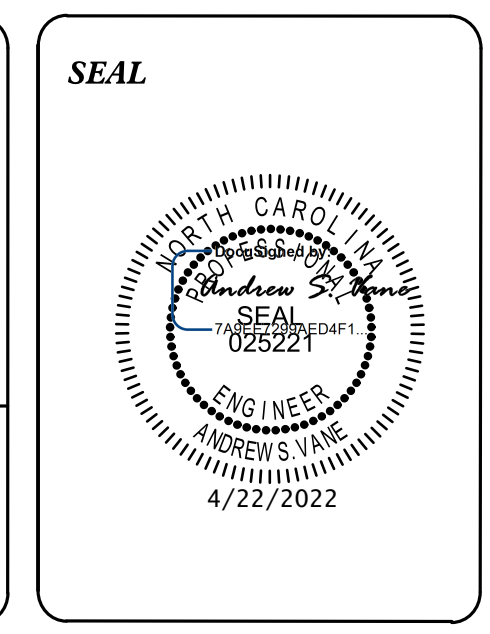

DIVISION OF HIGHWAYS UTILITIES UNIT
1555 MAIL SERVICES CENTER
RALEIGH, NC 27699-1555
PHONE (919) 707-6690
FAX (919) 250-4151











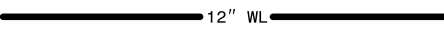













ALI KOUCHEKI UTILITIES REGIONAL ENGINEER
DAVID TRANTHAM UTILITIES ENGINEER
DAYTON MARTIN UTILITIES AREA COORDINATOR
LYNN BASINGER UTILITIES COORDINATOR

STATE OF NORTH CAROLINA DIVISION OF HIGHWAYS

PROJECT REFERENCE NO. 17BP.9.R.82	SHEET NO. UC-2
 STV 100 Years STV Engineers, Inc. 900 West Trade St., Suite 715 Charlotte, NC 28202 NC License Number F-0991	

UTILITIES PLAN SHEET SYMBOLS







PROPOSED WATER SYMBOLS



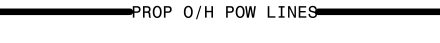
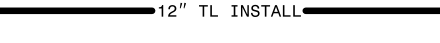

Water Line (Sized as Shown)	
11¼ Degree Bend	
22½ Degree Bend	
45 Degree Bend	
90 Degree Bend	
Plug	
Tee	
Cross	
Reducer	
Gate Valve	
Butterfly Valve	
Tapping Valve	
Line Stop	
Line Stop with Bypass	
Blow Off	
Fire Hydrant	
Relocate Fire Hydrant	
Remove Fire Hydrant	REM FH
Water Meter	
Relocate Water Meter	
Remove Water Meter	REM WM
Water Pump Station	
RPZ Backflow Preventer	
DCV Backflow Preventer	
Relocate RPZ Backflow Preventer	
Relocate DCV Backflow Preventer	

PROPOSED SEWER SYMBOLS

Gravity Sewer Line (Sized as Shown)	
Force Main Sewer Line (Sized as Shown)	
Manhole (Sized per Note)	
Sewer Pump Station	

PROPOSED MISCELLANEOUS UTILITIES SYMBOLS

Power Pole	
Telephone Pole	
Joint Use Pole	
Telephone Pedestal	
Utility Line by Others (Type as Shown)	
Trenchless Installation	
Encasement by Open Cut	
Encasement	

Thrust Block	
Air Release Valve	
Utility Vault	
Concrete Pier	
Steel Pier	
Plan Note	
Pay Item Note	

EXISTING UTILITIES SYMBOLS

Power Pole		*Underground Power Line	
Telephone Pole		*Underground Telephone Cable	
Joint Use Pole		*Underground Telephone Conduit	
Utility Pole		*Underground Fiber Optics Telephone Cable	
Utility Pole with Base		*Underground TV Cable	
H-Frame Pole		*Underground Fiber Optics TV Cable	
Power Transmission Line Tower		*Underground Gas Pipeline	
Water Manhole		Aboveground Gas Pipeline	
Power Manhole		*Underground Water Line	
Telephone Manhole		Aboveground Water Line	
Sanitary Sewer Manhole		*Underground Gravity Sanitary Sewer Line	
Hand Hole for Cable		Aboveground Gravity Sanitary Sewer Line	
Power Transformer		*Underground SS Forced Main Line	
Telephone Pedestal		Underground Unknown Utility Line	
CATV Pedestal		SUE Test Hole	
Gas Valve		Water Meter	
Gas Meter		Water Valve	
Located Miscellaneous Utility Object		Fire Hydrant	
Abandoned According to Utility Records	AATUR	Sanitary Sewer Cleanout	
End of Information	E.O.I.		

*For Existing Utilities
 Utility Line Drawn from Record (Type as Shown)
 Designated Utility Line (Type as Shown)

5/14/99

3/25/2022
 Projects\4018854_4018854_0001\50_Deliverables & Submittals\R.82_Bridge_248\Utilities\Engineering\UC\Proj\Sheets\R.82_ut_dtl_UC03A_psh.dgn

PROJECT TYPICAL DETAILS

PROJECT REFERENCE NO. 17BP.9.R.82	SHEET NO. UC-3B
DESIGNED BY: NKA	
DRAWN BY: NKA	
CHECKED BY: ASV	
APPROVED BY:	
REVISED:	
NORTH CAROLINA DEPARTMENT OF TRANSPORTATION UTILITIES ENGINEERING SEC. PHONE: (919) 707-6690 FAX: (919) 250-4151	
UTILITY CONSTRUCTION PLANS ONLY	

UTILITY CONSTRUCTION

STV 100 Years
 STV Engineers, Inc.
 900 West Trade St., Suite 715
 Charlotte, NC 28202
 NC License Number F-0991

**DOCUMENT NOT CONSIDERED FINAL
 UNLESS ALL SIGNATURES COMPLETED**

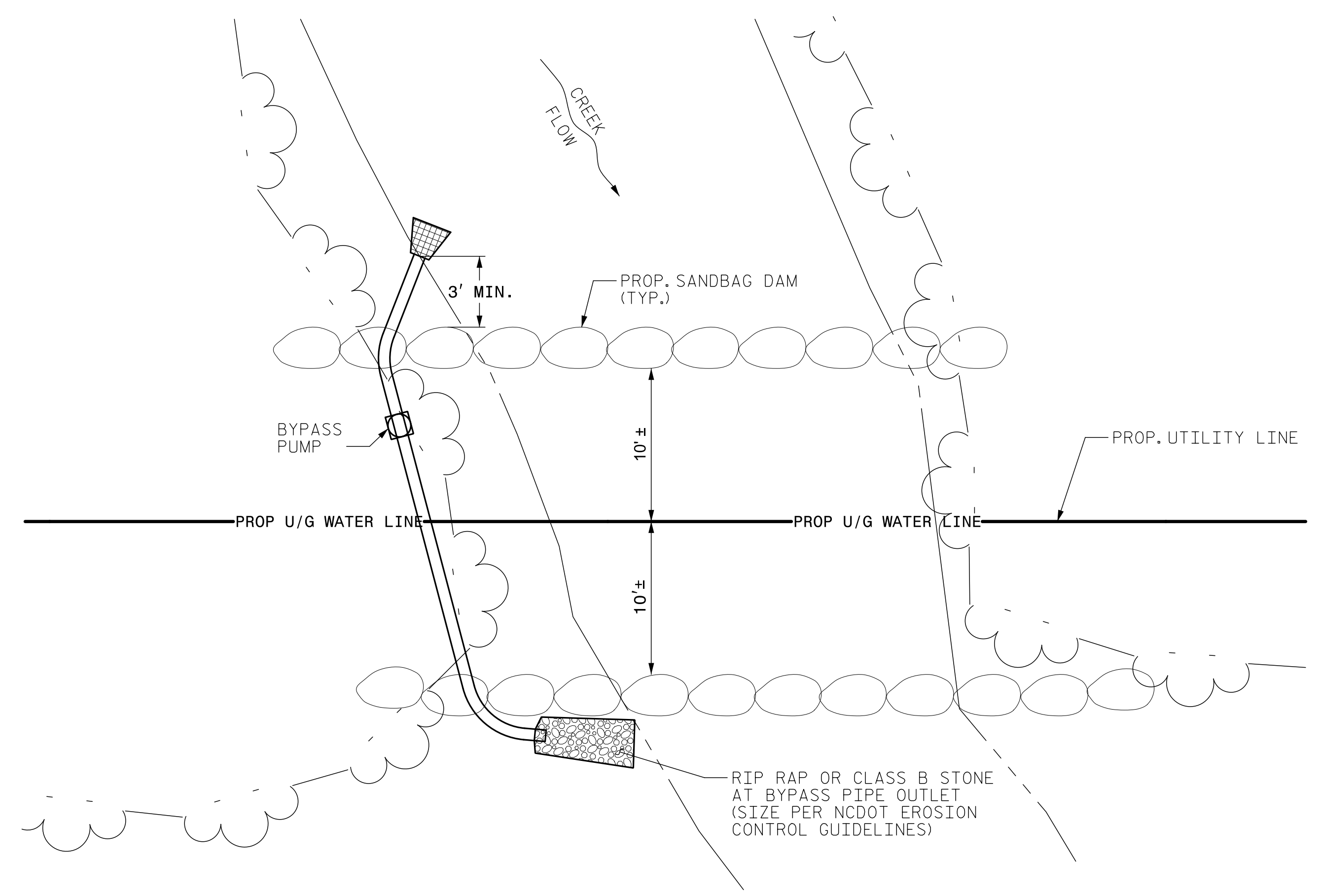

OPEN CUT CONSTRUCTION
 NOT TO SCALE

- NOTES:**
1. BASE FLOW OF STREAM WILL BE PUMPED AROUND WORK AREA AND RELEASED BACK INTO EXISTING STREAM BELOW THE WORK AREA ONTO RIP RAP OR CLASS B STONE PAD. BYPASS PUMP SHALL UTILIZE A FLOATING INTAKE.
 2. PUMP AROUND SYSTEM SHALL BE SUFFICIENT SIZE TO CARRY BASE STREAM FLOW.
 3. SANDBAG MATERIAL: SANDBAG SHALL BE WOVEN POLYPROPYLENE, POLYETHYLENE OR POLYAMIDE FABRIC, MINIMUM UNIT WEIGHT FOUR OUNCES PER SQUARE YARD, MULLEN BURST STRENGTH EXCEEDING 300 PSI IN CONFORMANCE WITH THE REQUIREMENTS IN ASTM DESIGNATION D3786, AND ULTRAVIOLET STABILITY EXCEEDING 70% IN CONFORMANCE WITH THE REQUIREMENTS IN ASTM DESIGNATION D4355. USE OF BURLAP IS NOT ACCEPTABLE.
 4. SAND FOR SANDBAGS SHALL BE A MINIMUM 110LB/CU. FT MATERIAL.
 5. THE CONTRACTOR SHALL TAKE WHATEVER PRECAUTIONS NECESSARY TO PROTECT THE EXISTING WATERLINE FROM LEAKS OR DAMAGE DURING THE EXCAVATION AND CONSTRUCTION OF THE PROPOSED WATERLINE.
 6. IT IS THE CONTRACTORS RESPONSIBILITY TO FOLLOW ALL OSHA AND STATE SAFETY REQUIREMENTS PERTAINING TO THIS EXCAVATION.
 7. ADDITIONAL EROSION CONTROL DEVICES MAY NEED TO BE INSTALLED AS DIRECTED BY THE DEPARTMENT.
 8. FOR NON-ROCK CREEK BOTTOMS, KEY SANDBAGS ON UPSTREAM SIDE 1' INTO SOIL.
 9. PERFORM CROSSING DURING ANTICIPATED DRY WEATHER ONLY. INSTALL PROPOSED UTILITY IN A DRY TRENCH.

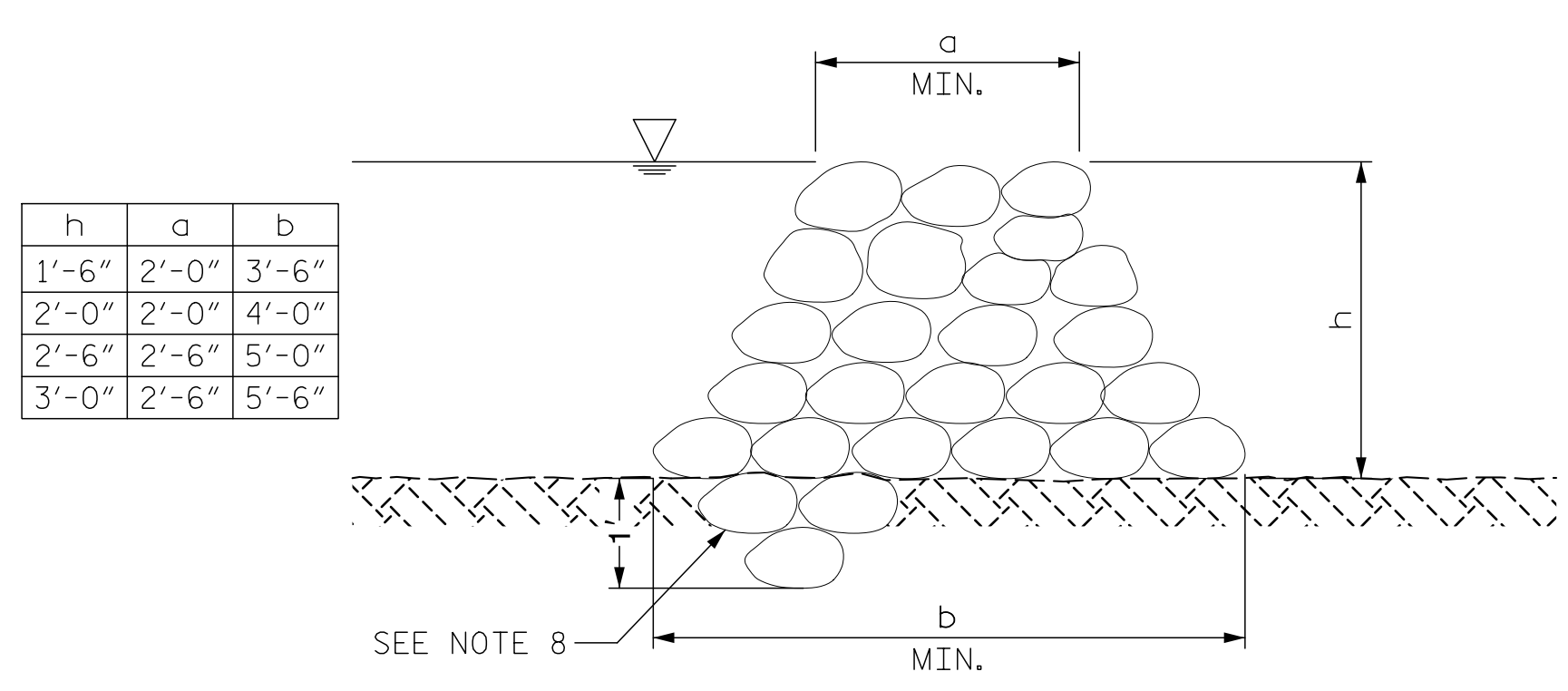

SANDBAG DAM SECTION

NOTE: SANDBAG DAM HEIGHT SHALL BE A MINIMUM OF 2'-6" UPSTREAM AND 1'-6" DOWNSTREAM. ADJUST FOR SITE CONDITIONS PRESENT DURING CONSTRUCTION.

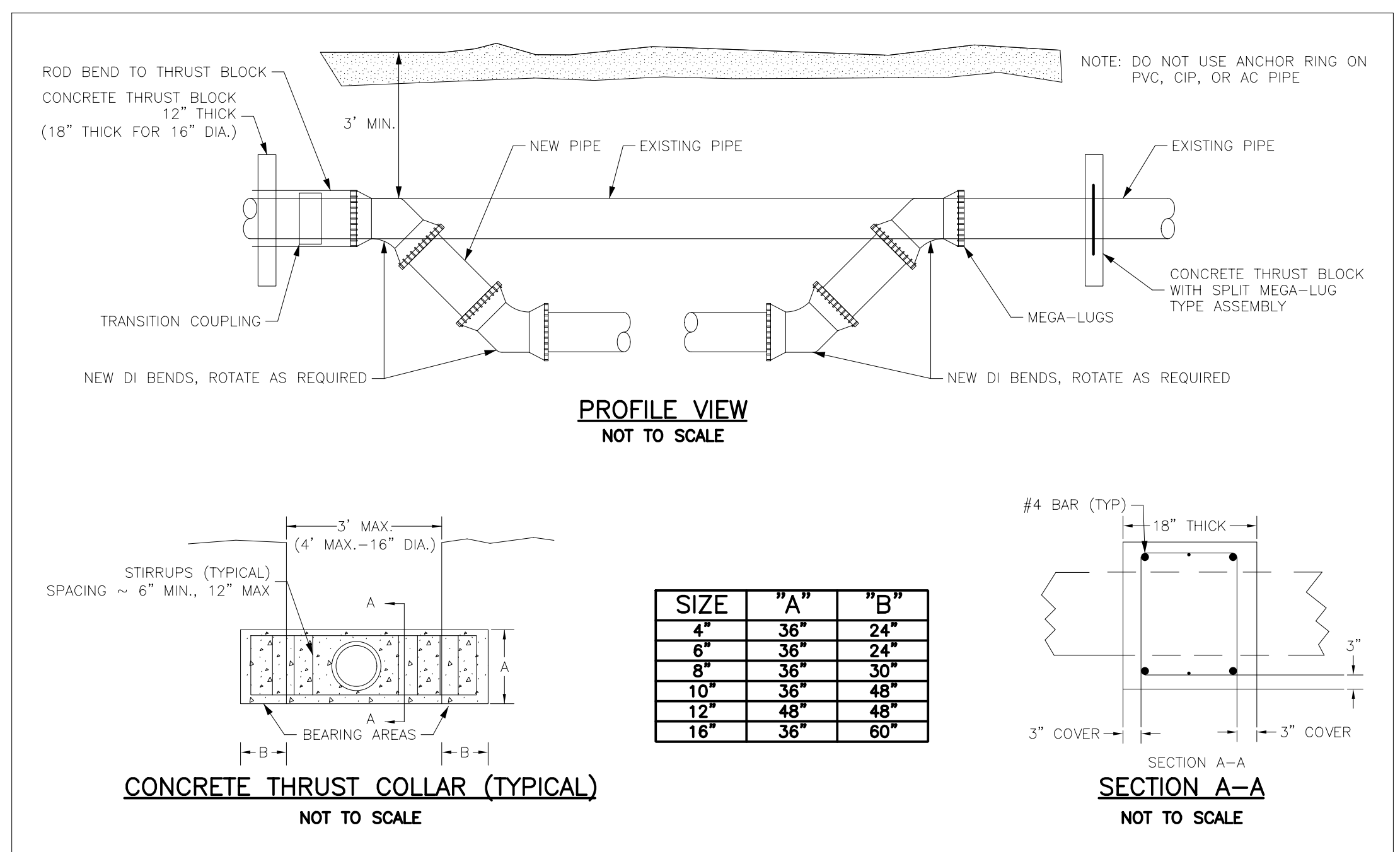
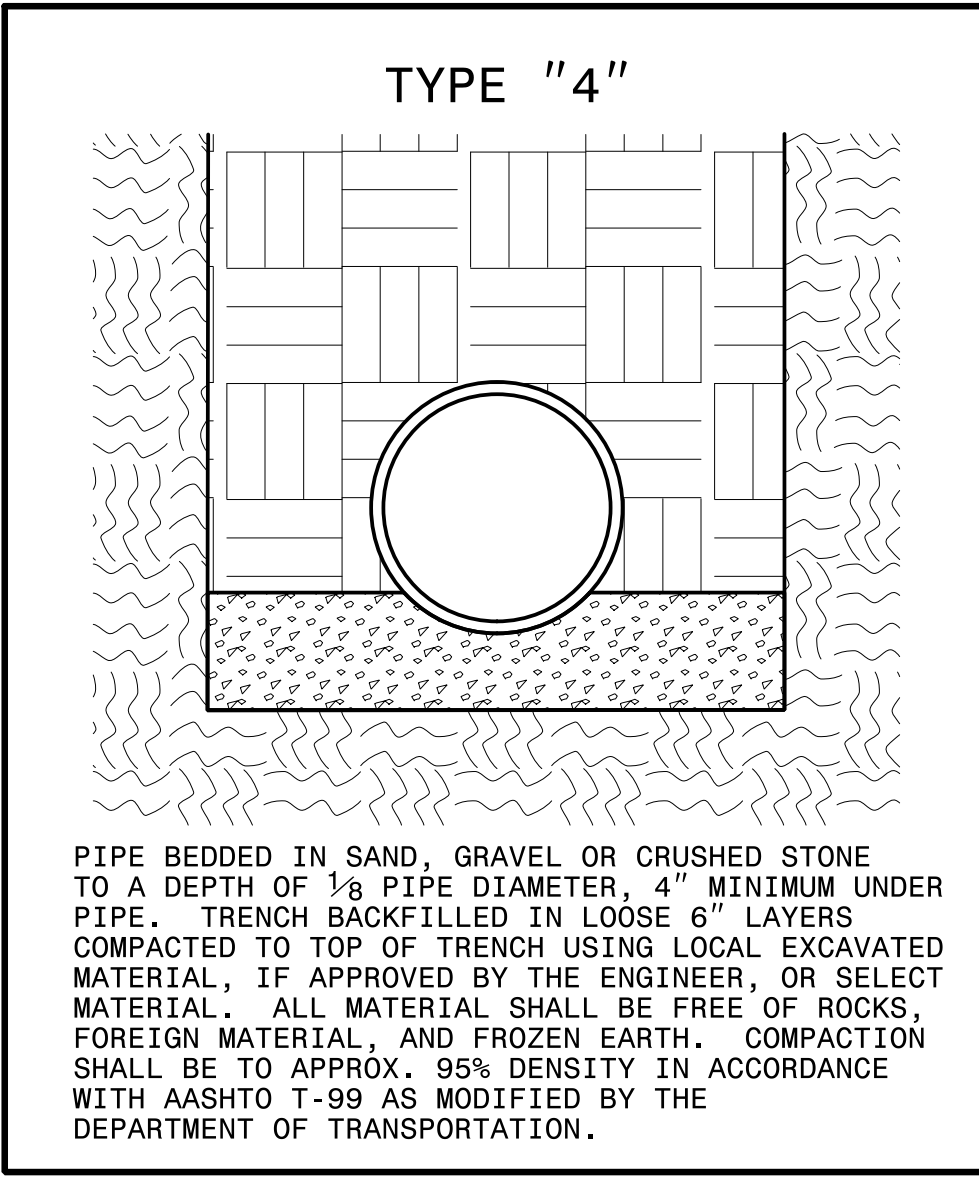

5/14/99

PROJECT REFERENCE NO.	SHEET NO.
17BP.9.R.82	UC-4
DESIGNED BY: NKA	
DRAWN BY: NKA	
CHECKED BY: ASV	
APPROVED BY:	
REVISED:	
NORTH CAROLINA DEPARTMENT OF TRANSPORTATION	
UTILITIES ENGINEERING SEC. PHONE: (919) 707-6690 FAX: (919) 250-4151	
UTILITY CONSTRUCTION PLANS ONLY	

UTILITY CONSTRUCTION

STV 100 Years
 STV Engineers, Inc.
 900 West Trade St., Suite 715
 Charlotte, NC 28202
 NC License Number F-0991

**DOCUMENT NOT CONSIDERED FINAL
 UNLESS ALL SIGNATURES COMPLETED**

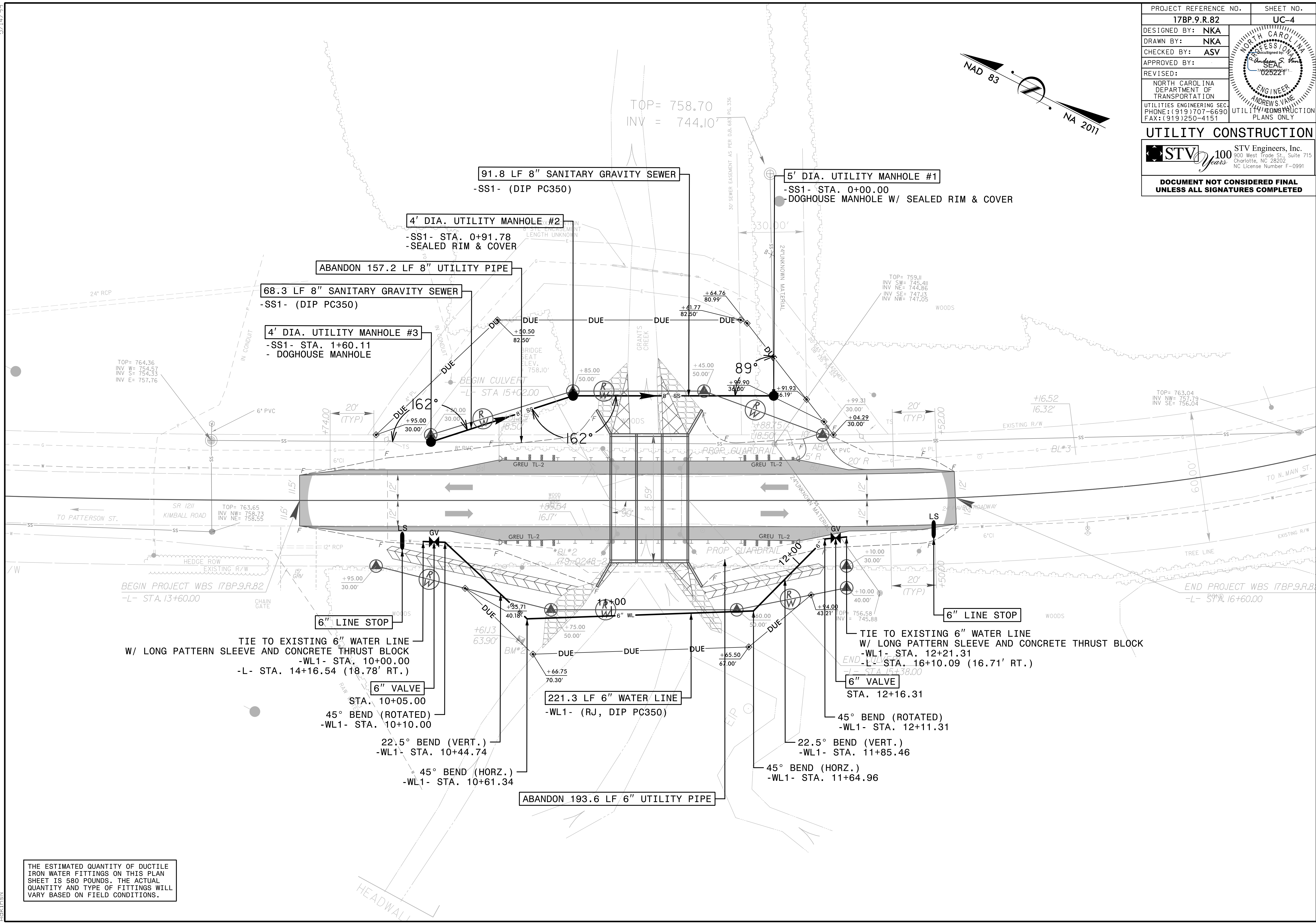
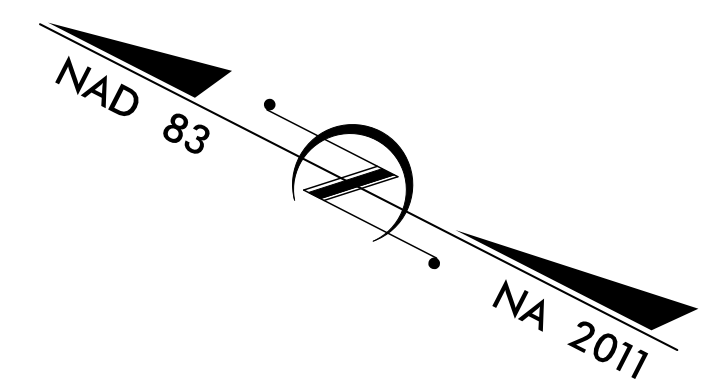

THE ESTIMATED QUANTITY OF DUCTILE IRON WATER FITTINGS ON THIS PLAN SHEET IS 580 POUNDS. THE ACTUAL QUANTITY AND TYPE OF FITTINGS WILL VARY BASED ON FIELD CONDITIONS.

3/25/2022
 C:\Projects\4018854\4018854_0001\50_Deliverables & Submittals\R.82_Bridge_248 Utilities Engineering\UC\ProJ\Sheets\R.82_uc\UC04_psh.dgn
 Adkins

5/28/99

SCALE: 1" = 20' HORIZONTAL
1" = 4' VERTICAL

NOTES:
1. LOCATION AND DEPTHS OF EXISTING UTILITIES ARE APPROXIMATE. CONTRACTOR TO FIELD VERIFY LOCATIONS AND DEPTHS PRIOR TO WATER LINE CONSTRUCTION.

PROP. 6" WATER LINE -WL1- GRANTS CREEK

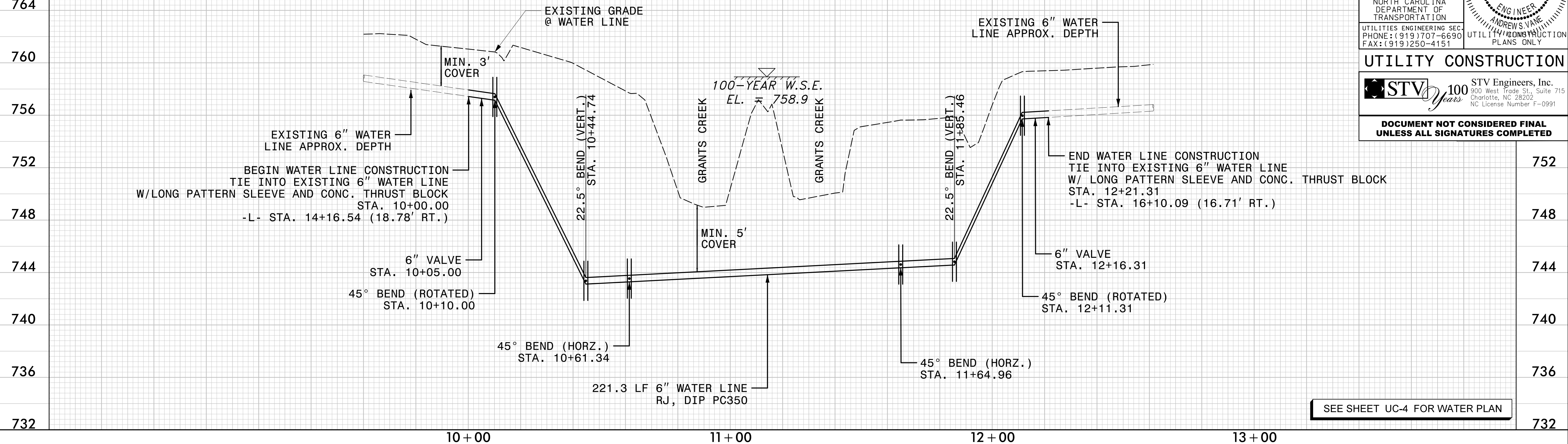

SEE SHEET UC-4 FOR WATER PLAN

PROJECT REFERENCE NO.	17BP.9.R.82	SHEET NO.	UC-5
DESIGNED BY:	NKA		
DRAWN BY:	NKA		
CHECKED BY:	ASV		
APPROVED BY:			
REVISED:			
NORTH CAROLINA DEPARTMENT OF TRANSPORTATION		UTILITIES ENGINEERING SECTION	
UTILITIES ENGINEERING SEC. PHONE: (919) 707-6690 FAX: (919) 250-4151		UTILITY CONSTRUCTION PLANS ONLY	

UTILITY CONSTRUCTION

STV 100 Years STV Engineers, Inc.
300 West Trade St., Suite 715
Charlotte, NC 28202
NC License Number F-0991

DOCUMENT NOT CONSIDERED FINAL UNLESS ALL SIGNATURES COMPLETED

SCALE: 1" = 20' HORIZONTAL
1" = 4' VERTICAL

NOTES:
1. LOCATION AND DEPTHS OF EXISTING UTILITIES ARE APPROXIMATE. CONTRACTOR TO FIELD VERIFY LOCATIONS AND DEPTHS PRIOR TO WATER LINE CONSTRUCTION.
2. TEMPORARY BYPASS PUMPING REQUIRED.

PROP. 8" SANITARY SEWER -SS1- GRANTS CREEK

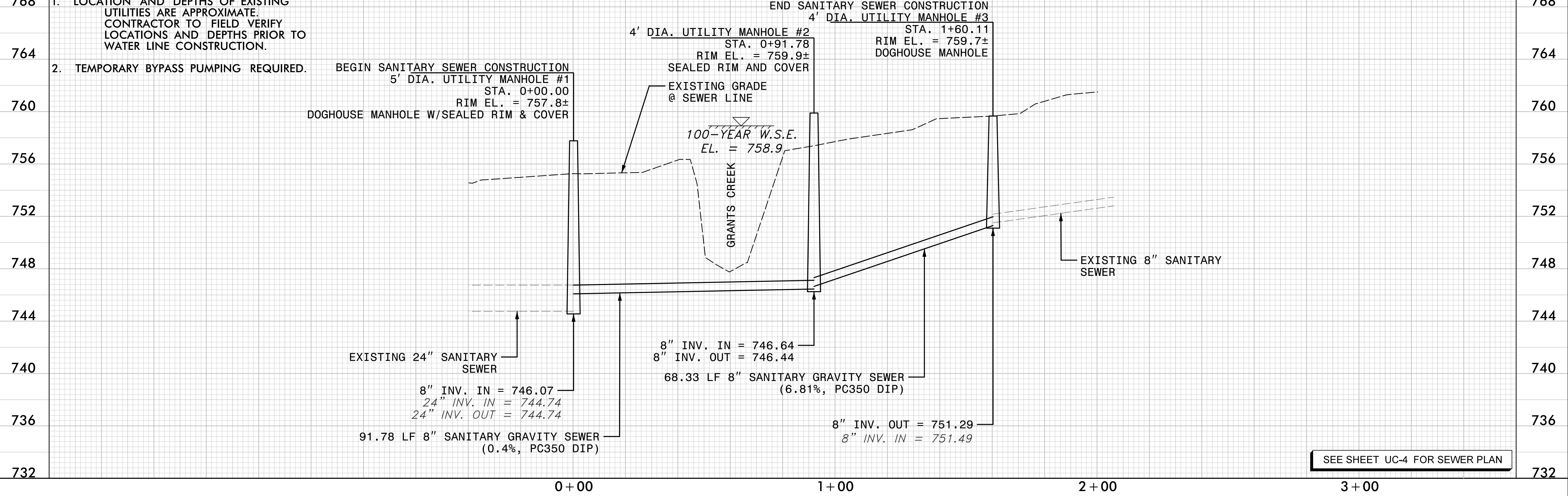

SEE SHEET UC-4 FOR SEWER PLAN

3/25/2022
I:\Projects\4018854\4018854_0001\50_Deliverables & Submittals\R.82_Bridge_248\Utilities\Engineering\UC\Proj\Sheets\R.82_ut_UC05_psh.dgn
Ackman

6/23/16

0	2.5	5	PROJ. REFERENCE NO.	SHEET NO.
			17BP.9.R.82	X-1

75 70 65 60 55 50 45 40 35 30 25 20 15 10 5 0 5 10 15 20 25 30 35 40 45 50 55 60 65 70 75

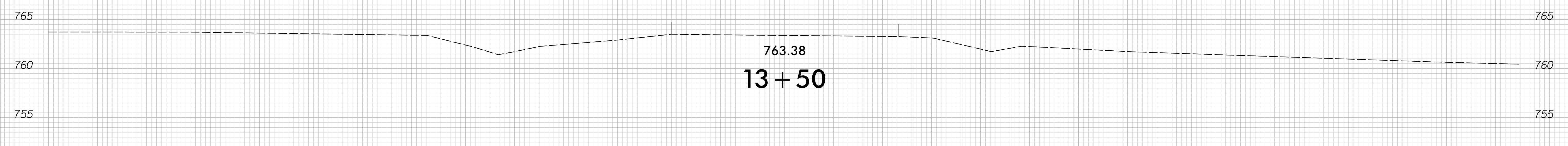
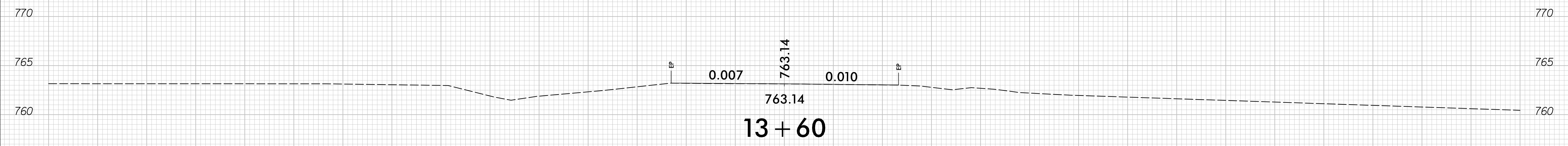
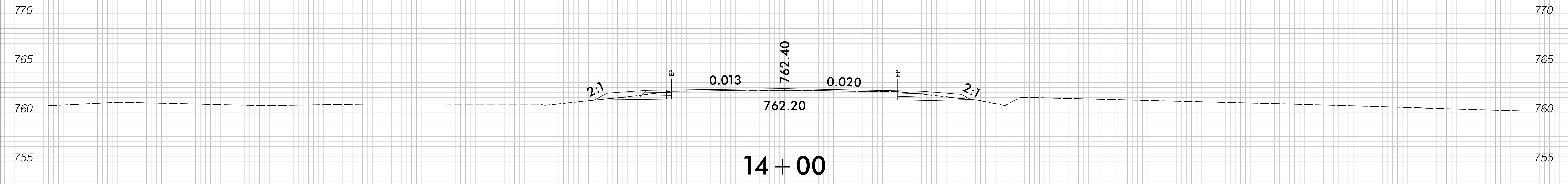

75 70 65 60 55 50 45 40 35 30 25 20 15 10 5 0 5 10 15 20 25 30 35 40 45 50 55 60 65 70 75

3/3/2022
C:\Users\yay\Xisc\R82_r.dwg_xpl.L.dgn

6/23/16

0 2.5 5	PROJ. REFERENCE NO. 17BP.9.R.82	SHEET NO. X-2
---------	------------------------------------	------------------

75 70 65 60 55 50 45 40 35 30 25 20 15 10 5 0 5 10 15 20 25 30 35 40 45 50 55 60 65 70 75

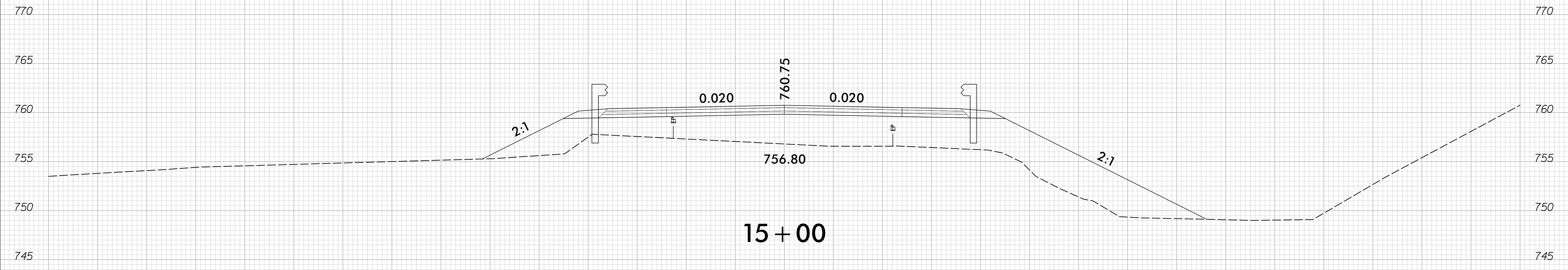

15 + 00

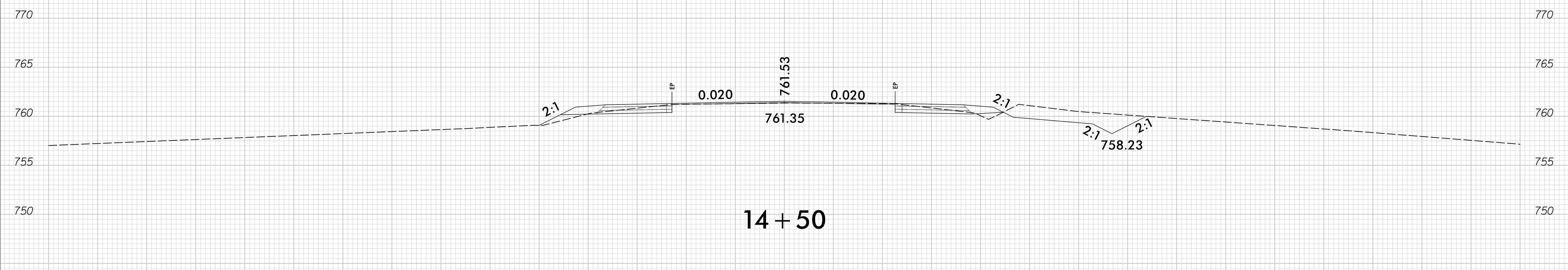

14 + 50

75 70 65 60 55 50 45 40 35 30 25 20 15 10 5 0 5 10 15 20 25 30 35 40 45 50 55 60 65 70 75

3/3/2022
C:\Users\yay\Xisc\R82_r.dwg_xpl.L.dgn

6/23/16

0 2.5 5	PROJ. REFERENCE NO. 17BP.9.R.82	SHEET NO. X-3
---------	------------------------------------	------------------

75 70 65 60 55 50 45 40 35 30 25 20 15 10 5 0 5 10 15 20 25 30 35 40 45 50 55 60 65 70 75

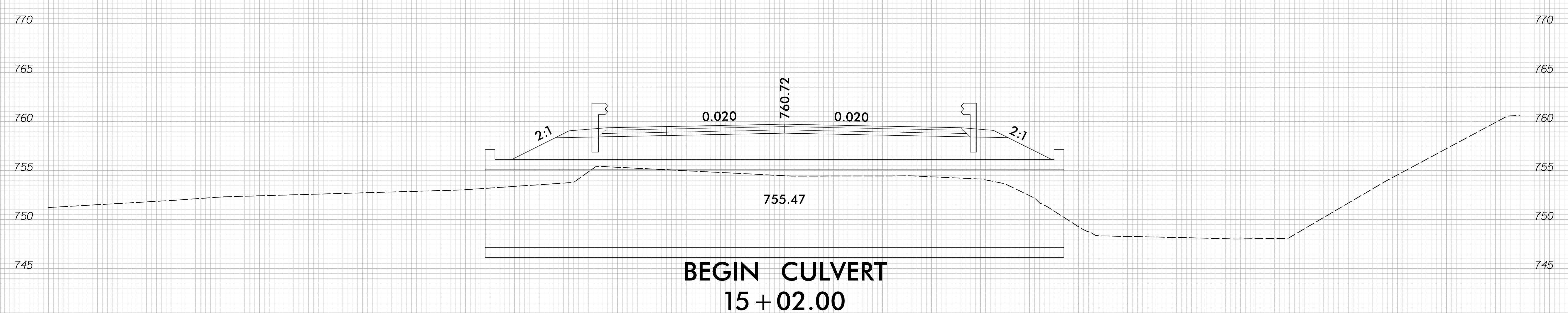
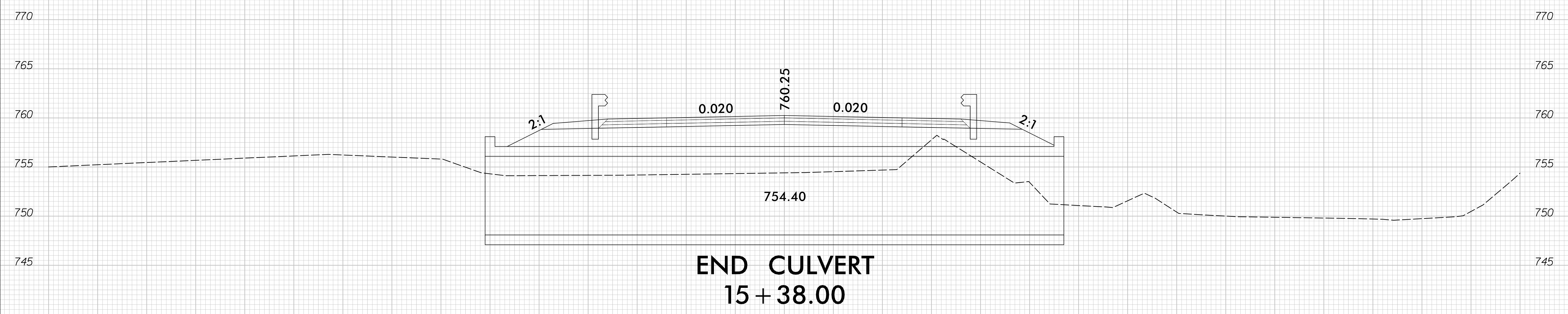

75 70 65 60 55 50 45 40 35 30 25 20 15 10 5 0 5 10 15 20 25 30 35 40 45 50 55 60 65 70 75

3/3/2022
C:\Users\yay\Xisc\R82_r.dwg_xpl.L.dgn
AutoCAD

6/23/16

0 2.5 5	PROJ. REFERENCE NO. 17BP.9.R.82	SHEET NO. X-4
---------	------------------------------------	------------------

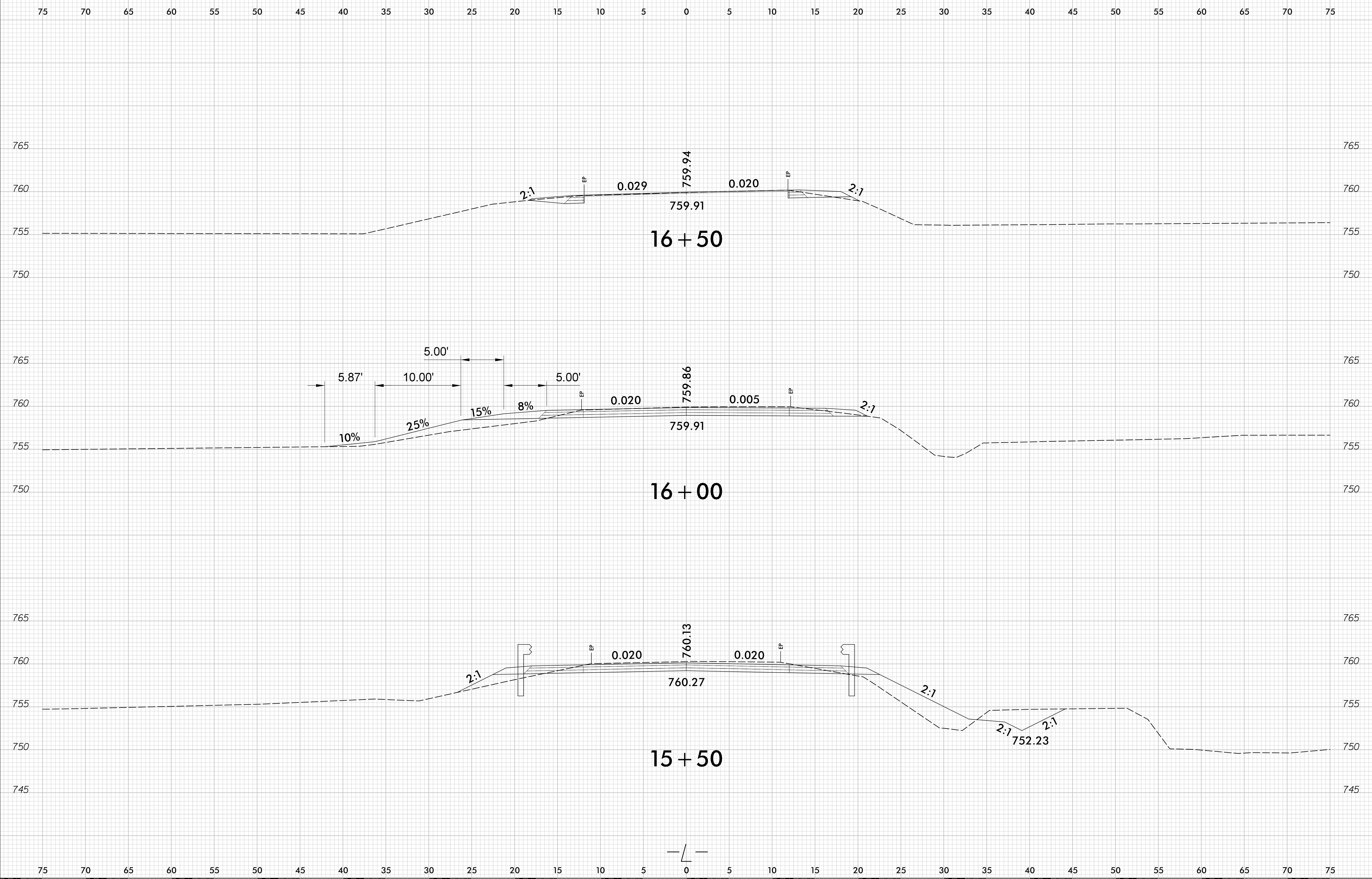

3/3/2022
C:\Users\yay\Xsc\R82_r.dwg - xpl.L.dgn
AutoCAD

6/23/16

0 2.5 5	PROJ. REFERENCE NO. 17BP.9.R.82	SHEET NO. X-5
---------	------------------------------------	------------------

75 70 65 60 55 50 45 40 35 30 25 20 15 10 5 0 5 10 15 20 25 30 35 40 45 50 55 60 65 70 75

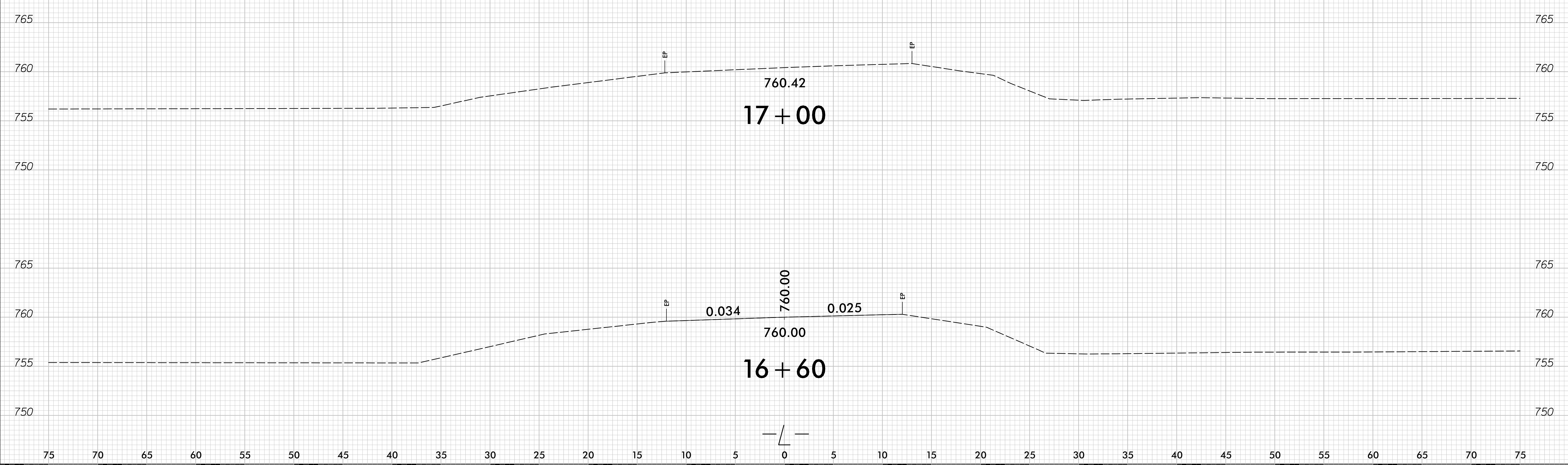

3/3/2022
C:\Users\j\OneDrive\Xisc\R82_r\dj_xpl.L.dgn

75 70 65 60 55 50 45 40 35 30 25 20 15 10 5 0 5 10 15 20 25 30 35 40 45 50 55 60 65 70 75

LOAD AND RESISTANCE FACTOR RATING (LRFR) SUMMARY FOR REINFORCED CONCRETE BOX CULVERTS

LEVEL	VEHICLE	WEIGHT (W) (TONS)	CONTROLLING LOAD RATING #	MINIMUM RATING FACTORS (RF)	TONS = W x RF	STRENGTH I LIMIT STATE								COMMENT NUMBER		
						LIVE-LOAD FACTORS (%LL)	MOMENT				SHEAR					
							RATING FACTOR	BOX NO.	ELEMENT TYPE	DISTANCE FROM LEFT END OF ELEMENT (±)	RATING FACTOR	BOX NO.	ELEMENT TYPE		DISTANCE FROM LEFT END OF ELEMENT (±)	
DESIGN LOAD RATING	HL-93 (INVENTORY)	N/A	1	1.26	--	1.75	1.38	1, 2 & 3	ROOF SLAB	11.75'	1.26	1, 2 & 3	ROOF SLAB	11.09'		
	HL-93 (OPERATING)	N/A		1.63	--	1.35	1.78	1, 2 & 3	ROOF SLAB	11.75'	1.63	1, 2 & 3	ROOF SLAB	11.09'		
	HS-20 (INVENTORY)	36.000	2	1.40	50.400	1.75	1.40	1, 2 & 3	ROOF SLAB	11.75'	1.44	1, 2 & 3	ROOF SLAB	11.09'		
	HS-20 (OPERATING)	36.000		1.81	65.160	1.35	1.81	1, 2 & 3	ROOF SLAB	11.75'	1.86	1, 2 & 3	ROOF SLAB	11.09'		
LEGAL LOAD RATING	SINGLE VEHICLE (SV)	SNSH		2.73	36.855	1.40	3.27	1, 2 & 3	ROOF SLAB	11.75'	2.73	1, 2 & 3	ROOF SLAB	11.09'		
		SNGARBS2	20.000		2.49	49.800	1.40	2.62	1, 2 & 3	ROOF SLAB	11.75'	2.49	1, 2 & 3	ROOF SLAB	11.09'	
		SNAGRIS2	22.000		2.54	55.880	1.40	2.54	1, 2 & 3	ROOF SLAB	11.75'	2.61	1, 2 & 3	ROOF SLAB	11.09'	
		SNCOTTS3	27.250		1.59	43.328	1.40	1.75	1, 2 & 3	ROOF SLAB	11.75'	1.59	1, 2 & 3	ROOF SLAB	11.09'	
		SNAGGRS4	34.925		1.74	60.770	1.40	1.74	1, 2 & 3	ROOF SLAB	11.75'	1.74	1, 2 & 3	ROOF SLAB	11.09'	
		SNS5A	35.550		1.72	61.146	1.40	1.78	1, 2 & 3	ROOF SLAB	11.75'	1.72	1, 2 & 3	ROOF SLAB	11.09'	
		SNS6A	39.950		1.69	67.516	1.40	1.72	1, 2 & 3	ROOF SLAB	11.75'	1.69	1, 2 & 3	ROOF SLAB	11.09'	
		SNS7B	42.000		1.64	68.880	1.40	1.64	1, 2 & 3	FLOOR SLAB	11.75'	1.69	1, 2 & 3	ROOF SLAB	11.09'	
	TRUCK TRACTOR SEMI-TRAILER (TTST)	TNAGRIT3	33.000		2.06	67.980	1.40	2.06	1, 2 & 3	FLOOR SLAB	11.75'	2.23	1, 2 & 3	FLOOR SLAB	11.15'	
		TNT4A	33.075		1.82	60.197	1.40	1.86	1, 2 & 3	ROOF SLAB	11.75'	1.82	1, 2 & 3	ROOF SLAB	11.09'	
		TNT6A	41.600		1.62	67.392	1.40	1.62	1, 2 & 3	FLOOR SLAB	11.75'	1.73	1, 2 & 3	ROOF SLAB	11.09'	
		TNT7A	42.000		1.70	71.400	1.40	1.70	1, 2 & 3	ROOF SLAB	11.75'	1.76	1, 2 & 3	ROOF SLAB	11.09'	
		TNT7B	42.000		1.75	73.500	1.40	1.78	1, 2 & 3	FLOOR SLAB	0.75'	1.75	1, 2 & 3	ROOF SLAB	11.09'	
		TNAGRIT4	43.000		1.65	70.950	1.40	1.65	1, 2 & 3	ROOF SLAB	11.75'	1.73	1, 2 & 3	FLOOR SLAB	11.15'	
		TNACT5A	45.000		1.54	69.300	1.40	1.54	1, 2 & 3	FLOOR SLAB	11.75'	1.63	1, 2 & 3	FLOOR SLAB	11.15'	
TNACT5B	45.000	3	1.43	64.350	1.40	1.43	1, 2 & 3	ROOF SLAB	11.75'	1.62	1, 2 & 3	FLOOR SLAB	11.15'			

LOAD FACTORS:

LOAD TYPE	MAX FACTOR	MIN FACTOR
DC	1.25	0.90
DW	1.50	0.65
EV	1.30	0.90
EH	1.35	0.90
ES	1.35	0.90
LS	1.75	--
WA	1.00	--

NOTE:

RATING FACTORS ARE BASED ON THE STRENGTH I LIMIT STATE.

COMMENTS:

- 1.
- 2.
- 3.
- 4.

CONTROLLING LOAD RATING

1 DESIGN LOAD RATING (HL-93)

2 DESIGN LOAD RATING (HS-20)

3 LEGAL LOAD RATING **

** SEE CHART FOR VEHICLE TYPE

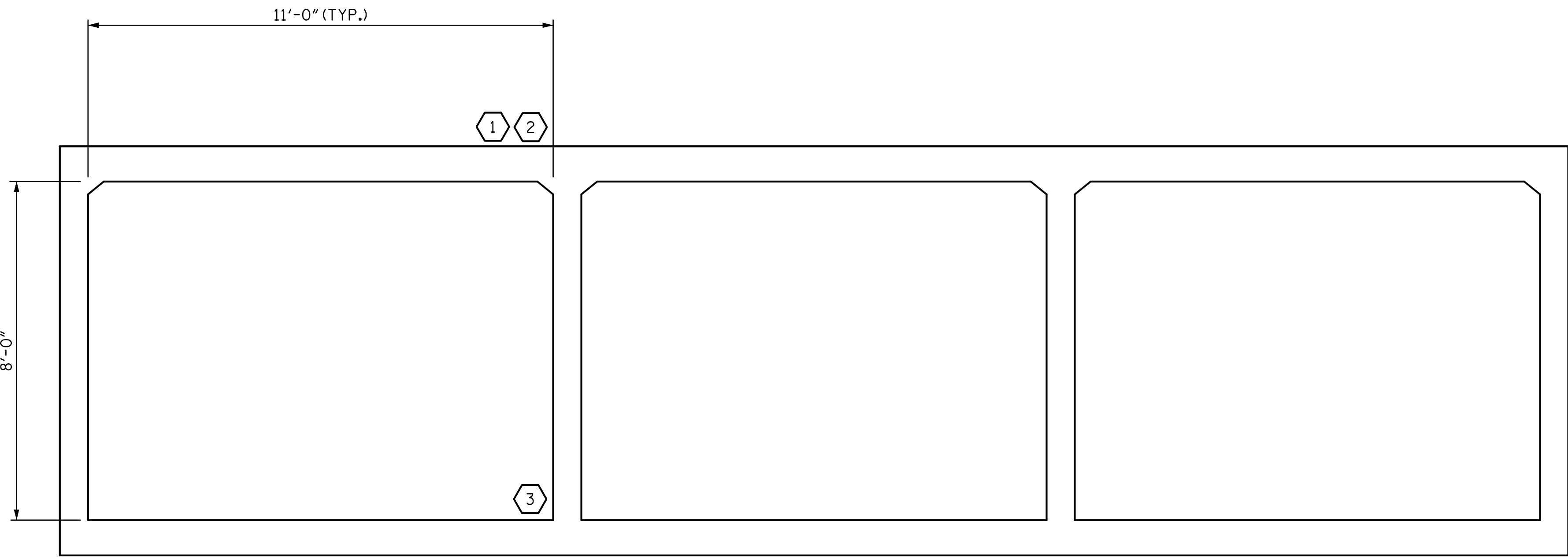

PROJECT NO. 17BP.9.R.82
ROWAN COUNTY
 STATION: 15+20.00 -L-

STATE OF NORTH CAROLINA
 DEPARTMENT OF TRANSPORTATION
 RALEIGH

**LRFR SUMMARY FOR
 REINFORCED CONCRETE
 BOX CULVERTS
 (NON-INTERSTATE TRAFFIC)**

STV 100 YEARS
 STV ENGINEERS, INC.
 900 West Trade St., Suite 715
 Charlotte, NC 28202
 NC License Number F-0991

DOCUMENT NOT CONSIDERED
 FINAL UNLESS ALL
 SIGNATURES COMPLETED

REVISIONS				SHEET NO.
NO.	BY:	DATE:	NO.	DATE:
1			3	
2			4	

C-2
TOTAL SHEETS
5

DRAWN BY : CL DATE : 11-18
 CHECKED BY : MLO DATE : 4-20
 DESIGN ENGINEER OF RECORD : LEM DATE : 12-21

LRFR SUMMARY

(LOOKING DOWNSTREAM)

12/8/2021 9:39:42 AM R:\Structures\Station\Finals\410_003_17BP.9.R.82_SMU_CU_002_790248.dgn

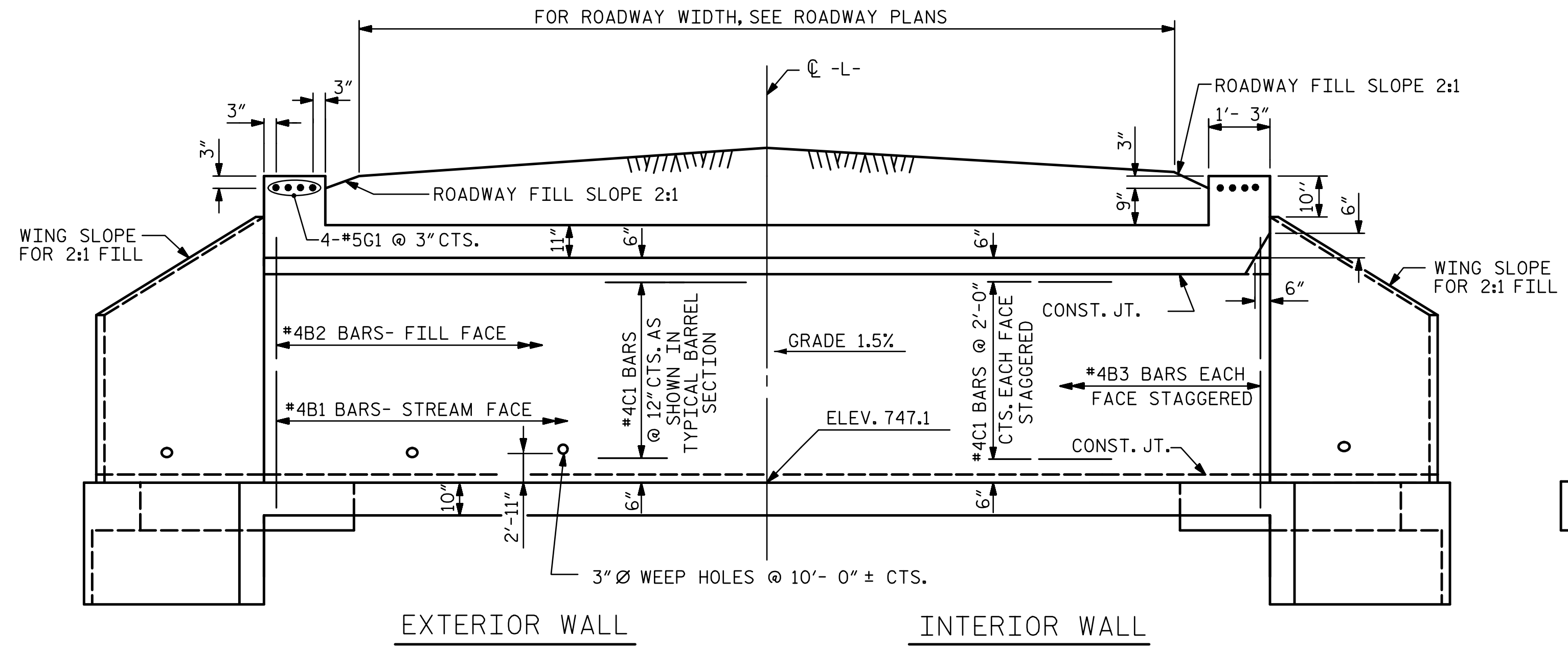

EXTERIOR WALL INTERIOR WALL
CULVERT SECTION NORMAL TO ROADWAY

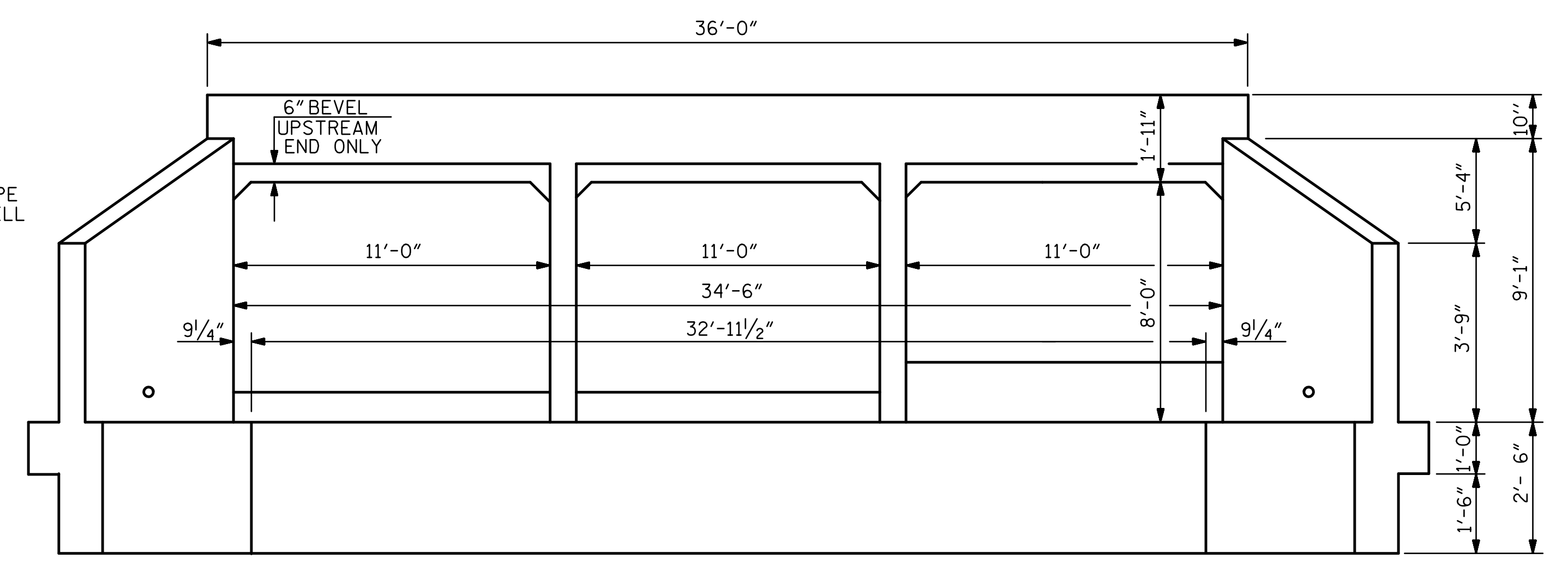

END ELEVATION
 (INLET END SHOWN, OUTLET END SIMILAR.)

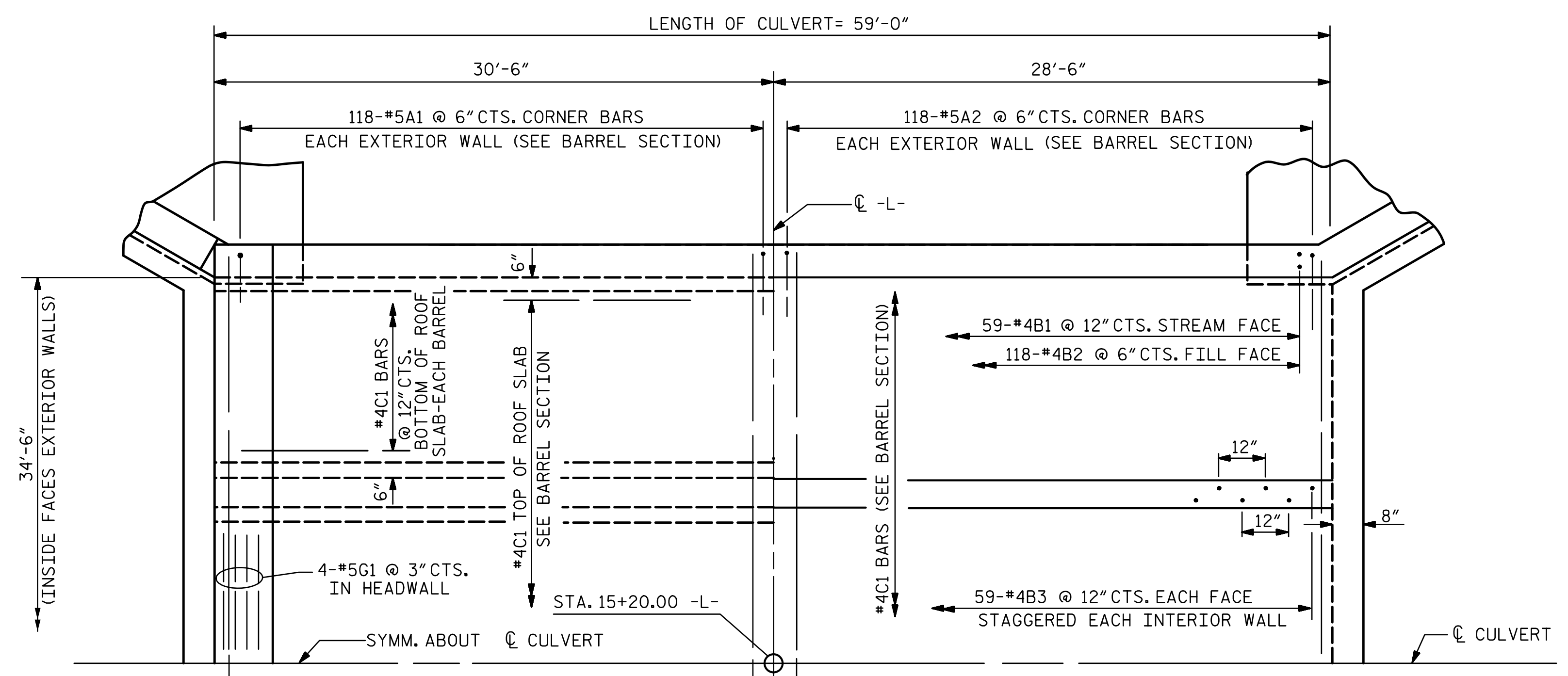

PART PLAN - ROOF SLAB **PART PLAN - FLOOR SLAB**

BAR TYPES		BILL OF REINFORCING FOR BARREL				
MARK	NO.	SIZE	TYPE	LENGTH	WEIGHT	
A1	236	#5	①	6'-7"	1,620	
A2	236	#5	①	6'-7"	1,620	
A100	118	#5	STR	35'-8"	4,390	
A200	236	#4	STR	18'-9"	2,956	
A300	118	#5	STR	35'-8"	4,390	
A400	118	#5	STR	35'-8"	4,390	
B1	118	#4	STR	9'-4"	736	
B2	236	#4	STR	7'-4"	1,156	
B3	236	#4	STR	9'-4"	1,471	
C1	378	#4	STR	21'-2"	5,345	
G1	8	#5	STR	35'-8"	298	
D1	8	#6	STR	2'-5"	29	
D2	16	#6	STR	1'-5"	34	
TOTAL BARREL REINFORCING STEEL =					28,435 LBS.	

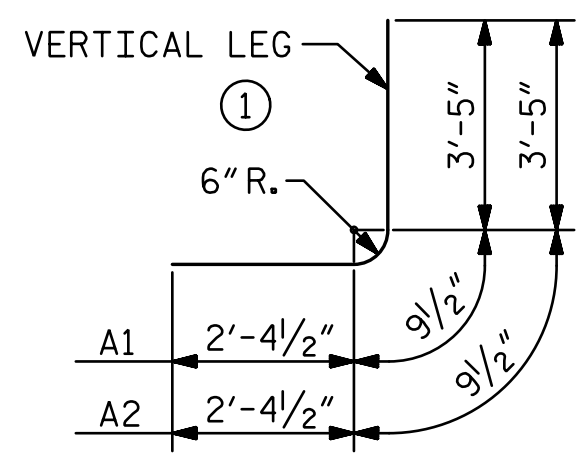

ALL BAR DIMENSIONS ARE OUT TO OUT.

PROJECT NO. 17BP.9.R.82
ROWAN COUNTY
 STATION: 15+20.00 -L-

STATE OF NORTH CAROLINA DEPARTMENT OF TRANSPORTATION RALEIGH				
TRIPLE 11'-0" X 8'-0" CONCRETE BOX CULVERT 90°-00'-00" SKEW				
REVISIONS				SHEET NO.
NO.	BY:	DATE:	NO.	BY:
1			3	
2			4	
				C-3
				TOTAL SHEETS 5

STV 100 YEARS STV ENGINEERS, INC.
 900 West Trade St., Suite 715
 Charlotte, NC 28202
 NC License Number F-0991

DOCUMENT NOT CONSIDERED
 FINAL UNLESS ALL
 SIGNATURES COMPLETED

R:\Structures\Station\Final\410_005_17BP.9.R.82_SMU_CU_003_790248.dgn 9:40:16 AM 12/8/2021 henselesg

DRAWN BY : CL DATE : 11-18
 CHECKED BY : MLO DATE : 4-20
 DESIGN ENGINEER OF RECORD : LEM DATE : 12-21

R:\Structures\Station\Finals\410_007_17BP.9.R.82_SMU_CU_004_790248.dgn 9:40:52 AM 12/8/2021 hensleg

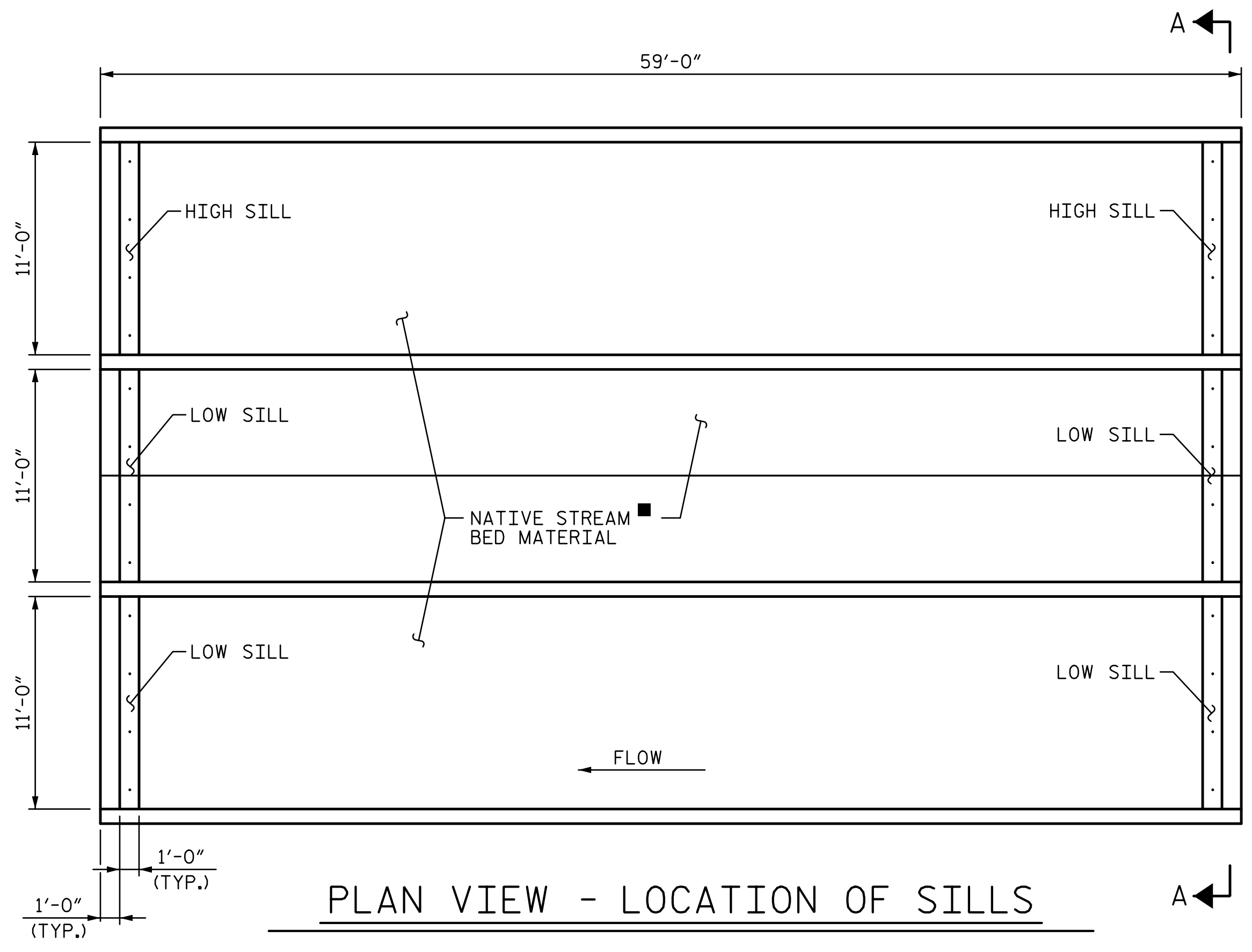

PLAN VIEW - LOCATION OF SILLS

■ NATIVE STREAM BED MATERIAL SHALL BE USED TO BACKFILL THE CULVERT BETWEEN SILLS. (SEE NOTE ON SHEET C-1)

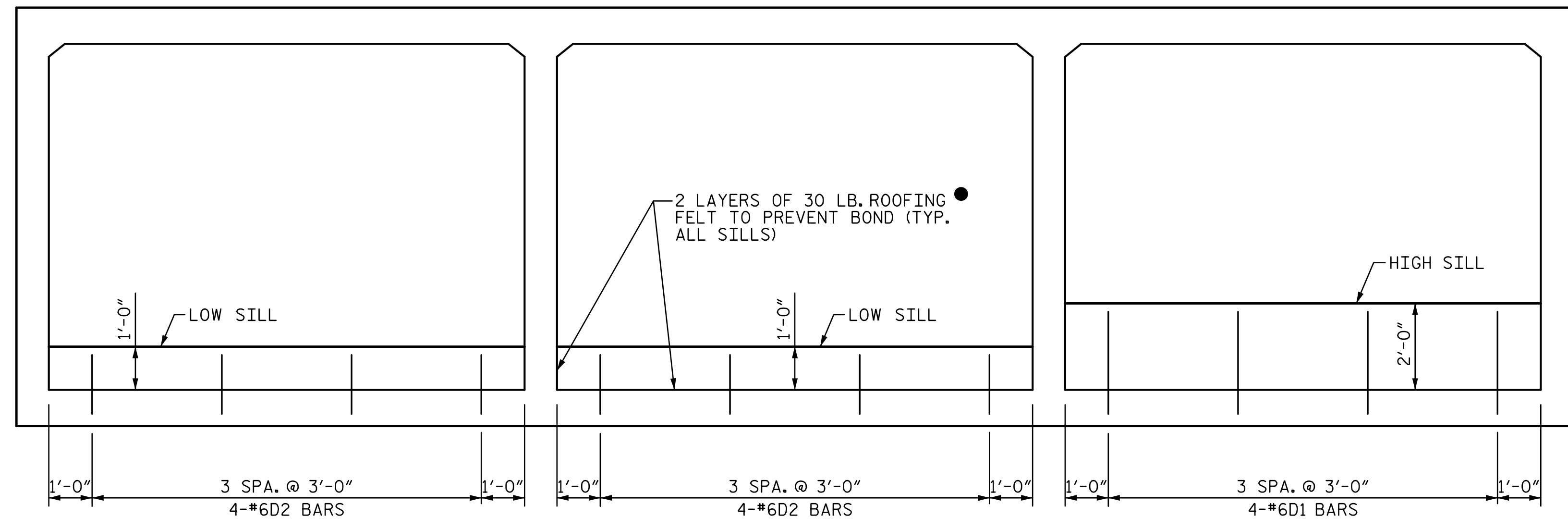

SECTION A-A

SECTION AT INLET SHOWN. SECTION AT OUTLET SIMILAR.
● THE COST OF THE ROOFING FELT IS INCIDENTAL AND SHALL BE INCLUDED IN THE VARIOUS PAY ITEMS.

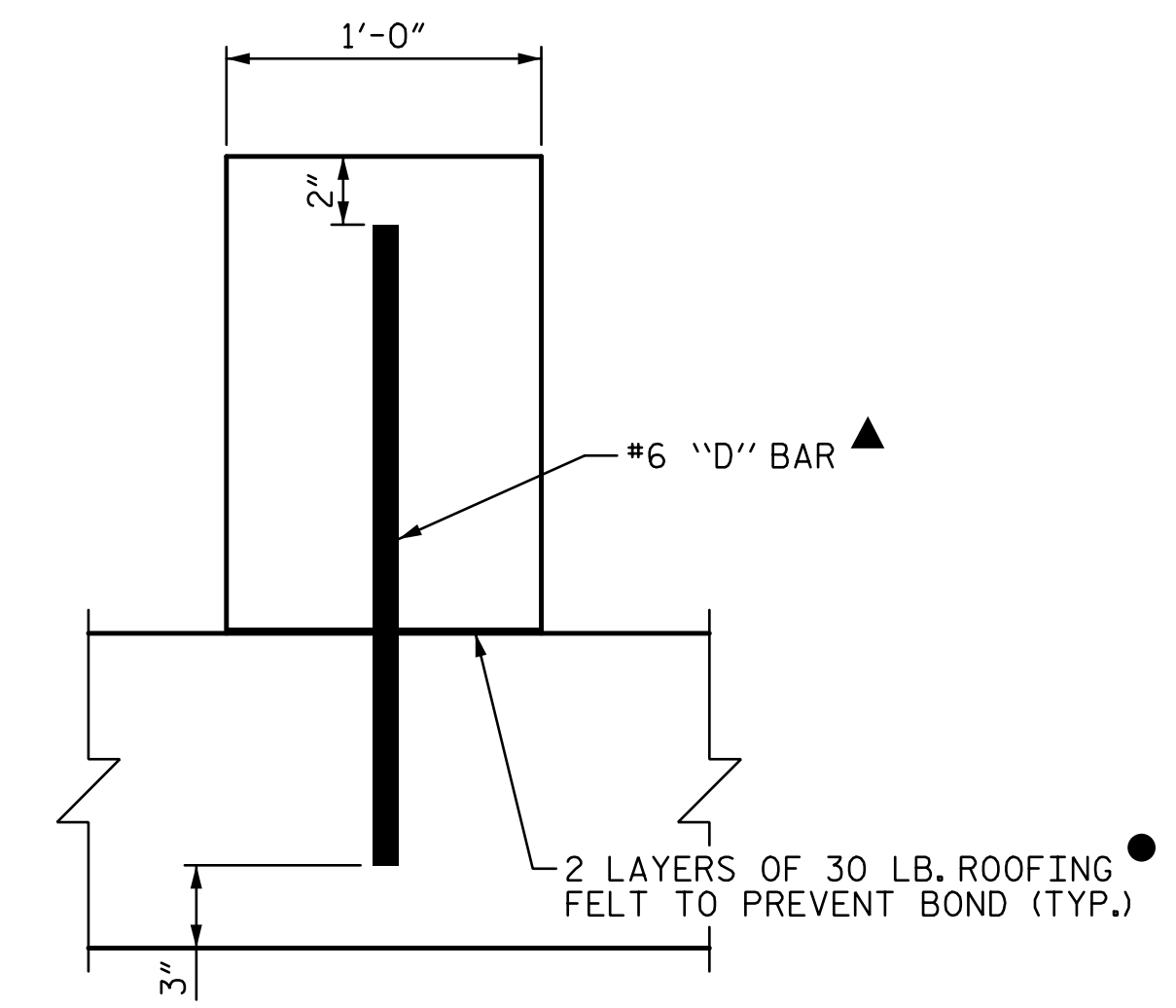

SECTION THROUGH SILL

▲ DOWELS MAY BE PUSHED INTO GREEN CONCRETE AFTER SLAB HAS BEEN FLOAT FINISHED.

PROJECT NO. 17BP.9.R.82
ROWAN COUNTY
STATION: 15+20.00 -L-

STATE OF NORTH CAROLINA DEPARTMENT OF TRANSPORTATION RALEIGH					
SILL DETAILS					
REVISIONS					SHEET NO.
NO.	BY:	DATE:	NO.	BY:	DATE:
1			3		
2			4		
					C-4
					TOTAL SHEETS
					5

STV 100 Years
STV ENGINEERS, INC.
900 West Trade St., Suite 715
Charlotte, NC 28202
NC License Number F-0991

DOCUMENT NOT CONSIDERED
FINAL UNLESS ALL
SIGNATURES COMPLETED

DRAWN BY :	CL	DATE :	11-18
CHECKED BY :	MLO	DATE :	4-20
DESIGN ENGINEER OF RECORD :	LEM	DATE :	12-21

12/8/2021 4:31:29 PM R:\Structures\Station\Finals\410_009_17BP.9.R.82_SMU_CU_005_730248.dgn

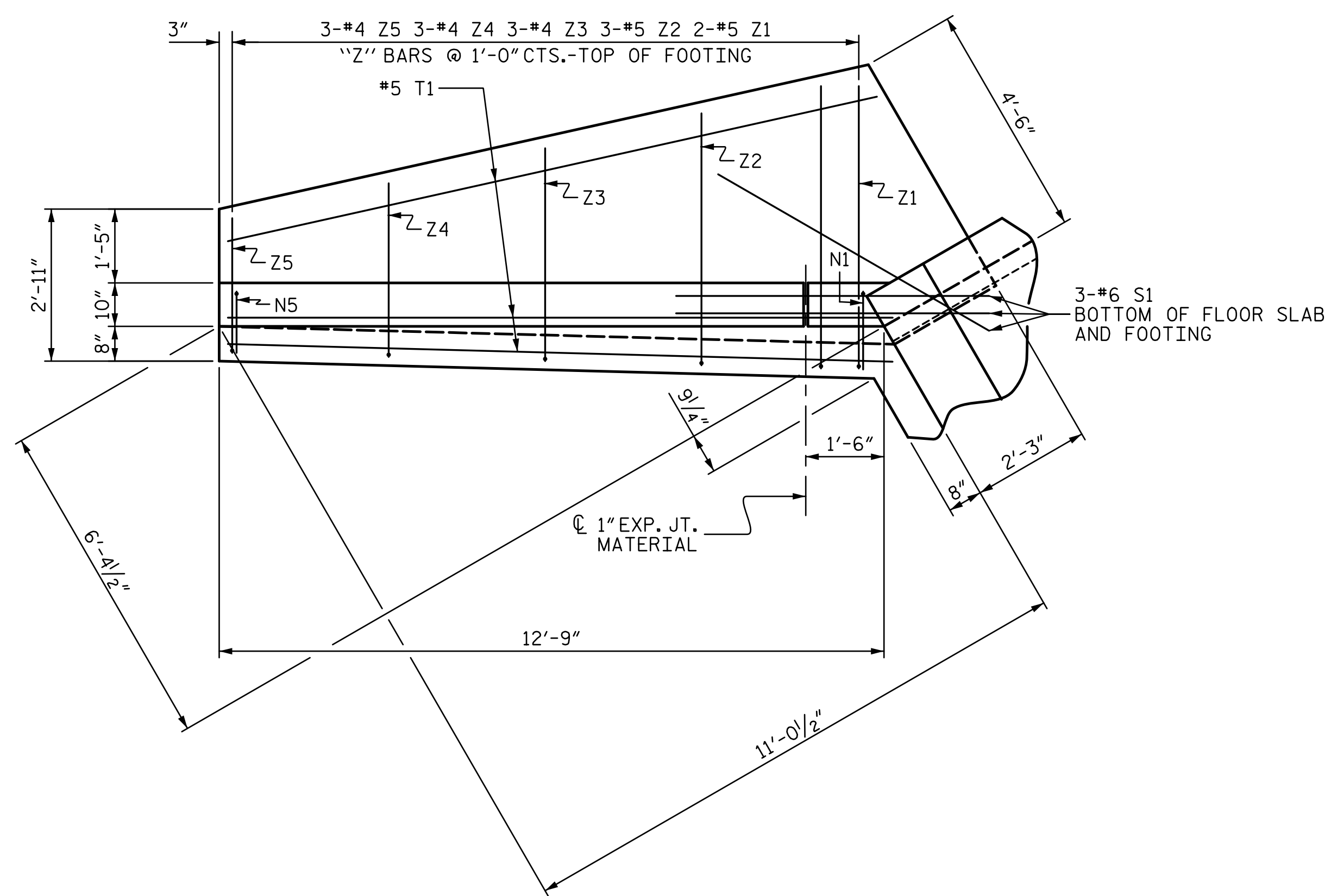

PLAN

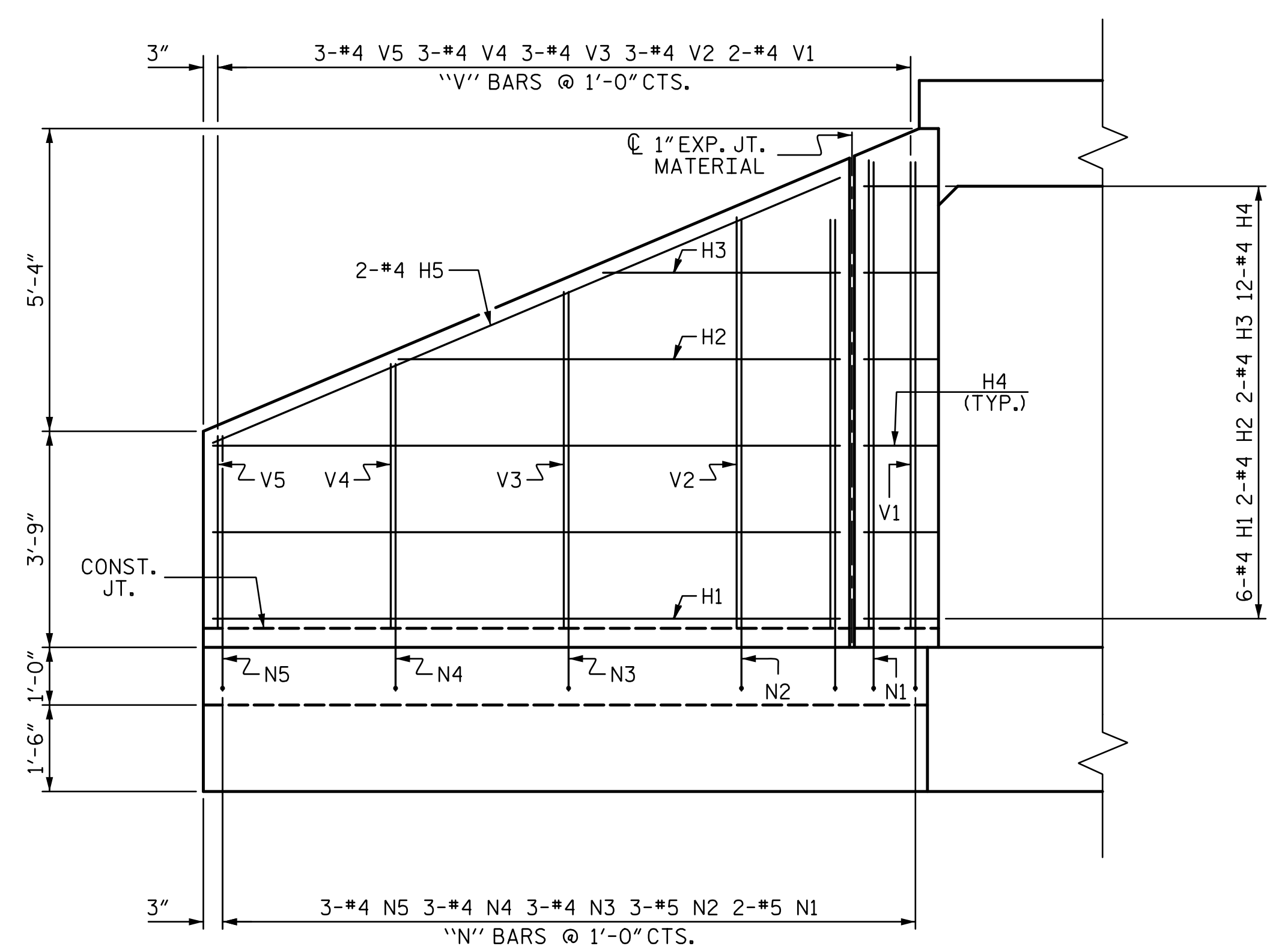

ELEVATION

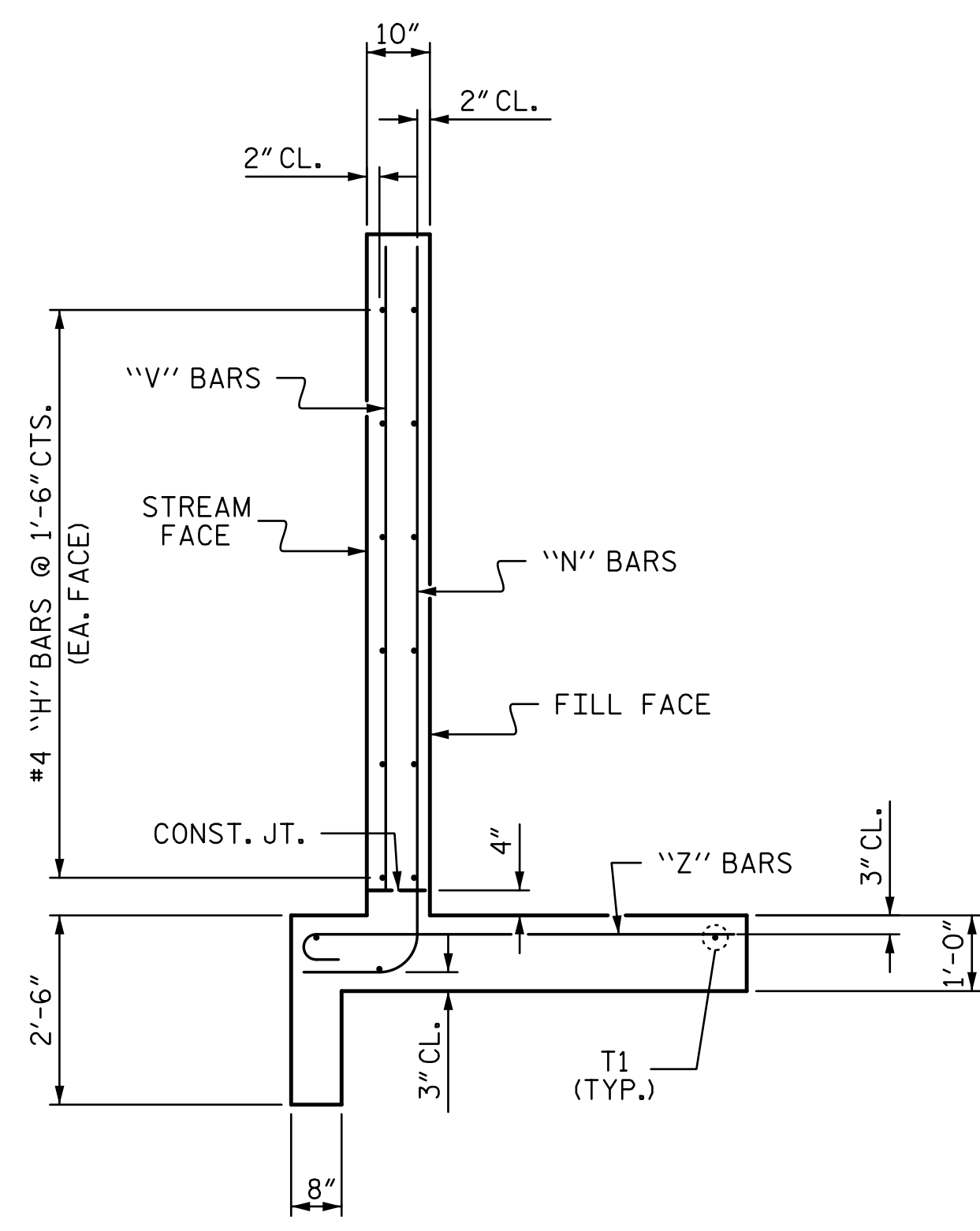

TYPICAL WING SECTION

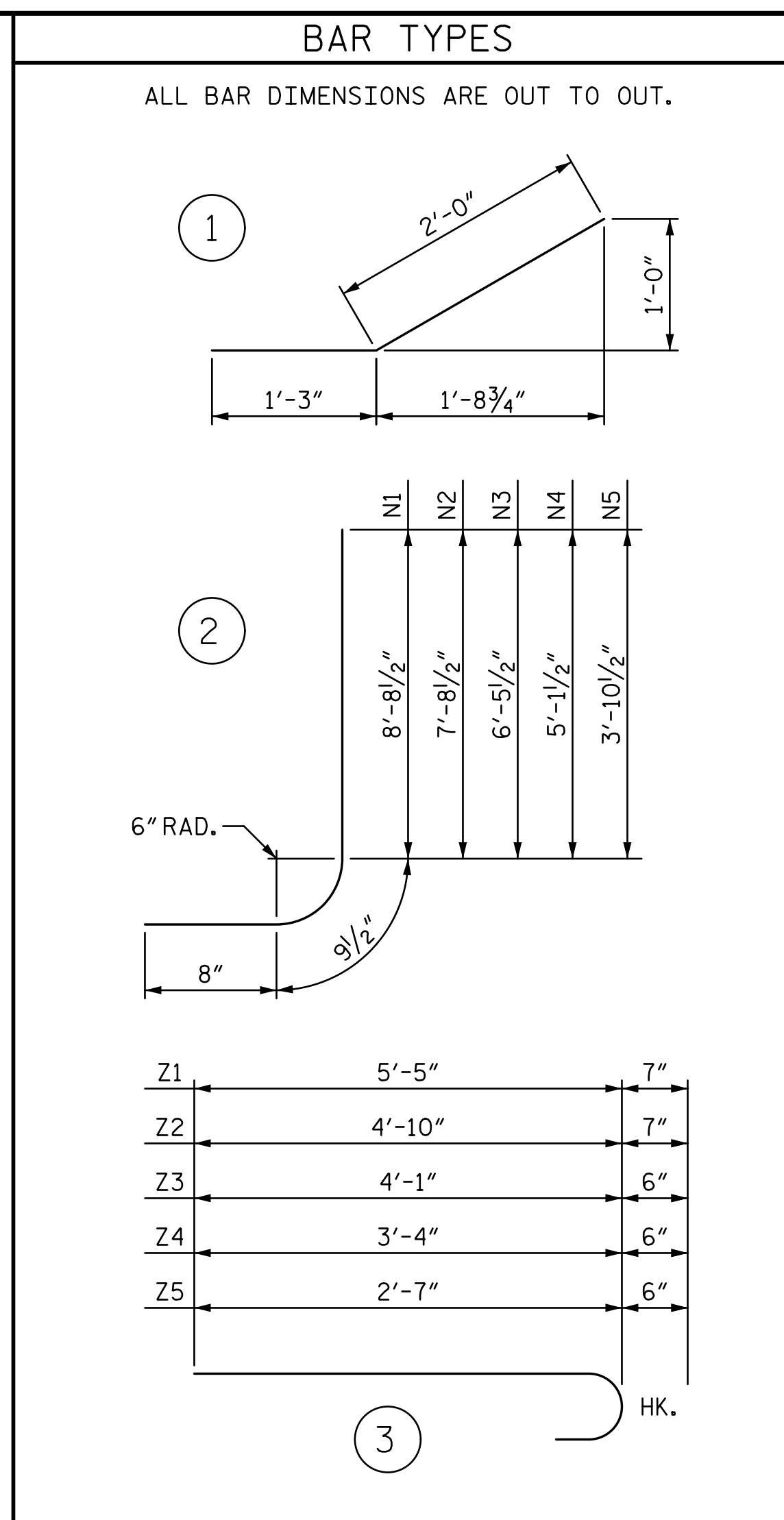

BILL OF MATERIAL					
BAR	NO.	SIZE	TYPE	LENGTH	WEIGHT
H1	24	#4	STR	10'-10"	174
H2	8	#4	STR	7'-8"	41
H3	8	#4	STR	4'-1"	22
H4	48	#4	1	3'-3"	104
H5	8	#4	STR	11'-9"	63
N1	8	#5	2	10'-2"	85
N2	12	#5	2	9'-2"	115
N3	12	#4	2	7'-11"	63
N4	12	#4	2	6'-7"	53
N5	12	#4	2	5'-4"	43
S1	12	#6	STR	6'-0"	108
T1	12	#5	STR	12'-9"	160
V1	8	#4	STR	8'-1"	43
V2	12	#4	STR	7'-1"	57
V3	12	#4	STR	5'-10"	47
V4	12	#4	STR	4'-7"	37
V5	12	#4	STR	3'-4"	27
Z1	8	#5	3	6'-0"	50
Z2	12	#5	3	5'-5"	68
Z3	12	#4	3	4'-7"	37
Z4	12	#4	3	3'-10"	31
Z5	12	#4	3	3'-1"	25
REINFORCING STEEL FOR 4 WINGS				1,453	LBS
CLASS A CONCRETE					
4 WINGS				21.3	CY
2 HEADWALLS				3.3	CY
2 END CURTAIN WALLS				4.1	CY
6 SILLS				3.3	CY
TOTAL				32.0	CY

PROJECT NO. 17BP.9.R.82
ROWAN COUNTY
 STATION: 15+20.00 -L-

STATE OF NORTH CAROLINA
 DEPARTMENT OF TRANSPORTATION
 RALEIGH
STANDARD WINGS FOR CONCRETE BOX CULVERT
 H=8'-0" SLOPE=2:1
 90° SKEW

DRAWN BY :	CL	DATE :	11-18
CHECKED BY :	MLO	DATE :	4-20
DESIGN ENGINEER OF RECORD :	LEM	DATE :	12-21

DOCUMENT NOT CONSIDERED FINAL UNLESS ALL SIGNATURES COMPLETED

REVISIONS				SHEET NO.
NO.	BY:	DATE:	NO.	DATE:
1			3	
2			4	

TOTAL SHEETS	5
--------------	---

STV 100 YEARS
 STV ENGINEERS, INC.
 900 West Trade St., Suite 715
 Charlotte, NC 28202
 NC License Number F-0991

